

## Features

- Meets applicable requirements of CCITT G.704, G.706, G.732, G.775, G.796, I.431 and ETSI ETS 300 011
- HDB3, RZ, NRZ (fibre interface) and bipolar NRZ line codes
- Data link access and national bit buffers (five bytes each)
- Enhanced alarms, performance monitoring and error insertion
- Maskable interrupts for alarms, receive CAS bit changes, exception conditions and counter overflows
- Automatic interworking between CRC-4 and non-CRC-4 multiframing
- Dual transmit and receive 16 byte circular channel buffers
- Two frame receive elastic buffer with controlled slip direction indication and 26 channel hysteresis (208 UI wander tolerance)
- CRC-4 updating algorithm for intermediate path points of a message-based data link application

## Applications

- Primary rate ISDN network nodes
- Digital Access Cross-connect (DACs)
- CO and PABX switching equipment interfaces
- E1 add/drop multiplexers and channel banks
- Test equipment and satellite interfaces

### Ordering Information

MT9079AE	40 Pin Plastic DIP
MT9079AL	44 Pin QFP
MT9079AP	44 Pin PLCC
<b>-40° to 85°C</b>	

## Description

The MT9079 is a feature rich E1 (PCM 30, 2.048 Mbps) link framer and controller that meets the latest CCITT and ETSI requirements.

The MT9079 will interface to a 2.048 Mbps backplane and can be controlled directly by a parallel processor, serial controller or through the ST-BUS.

Extensive alarm transmission and reporting, as well as exhaustive performance monitoring and error diagnostic features make this device ideal for a wide variety of applications.

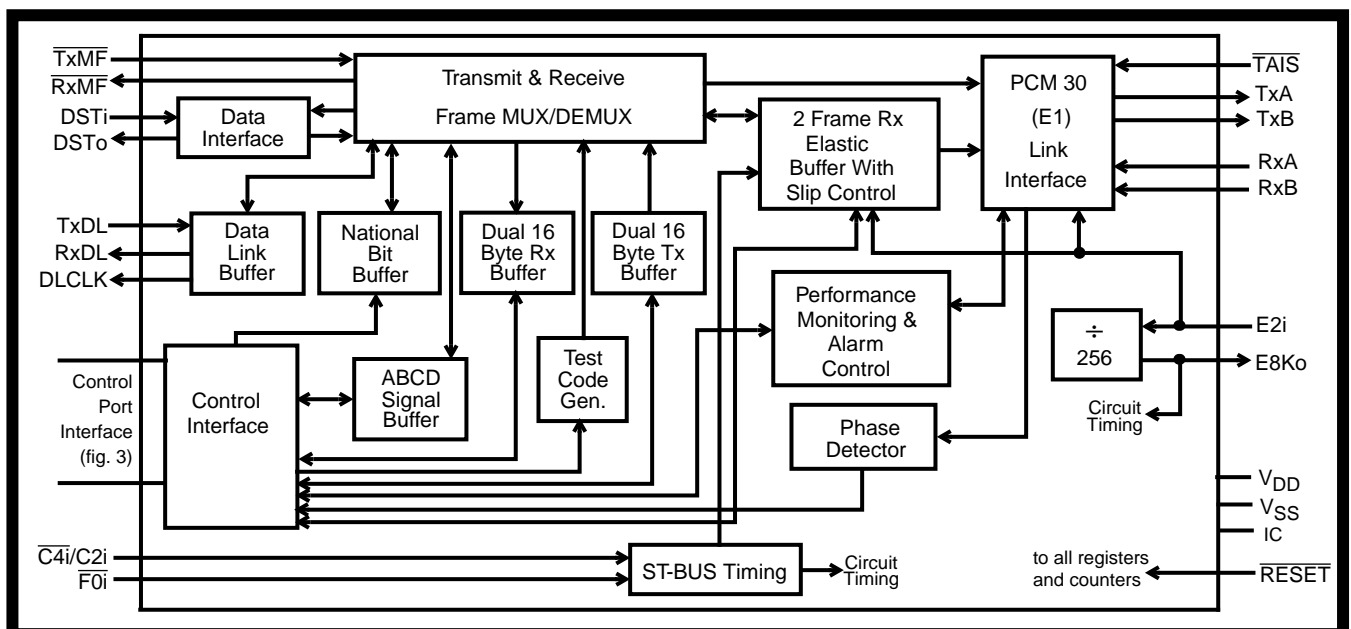

**Figure 1 - Functional Block Diagram**

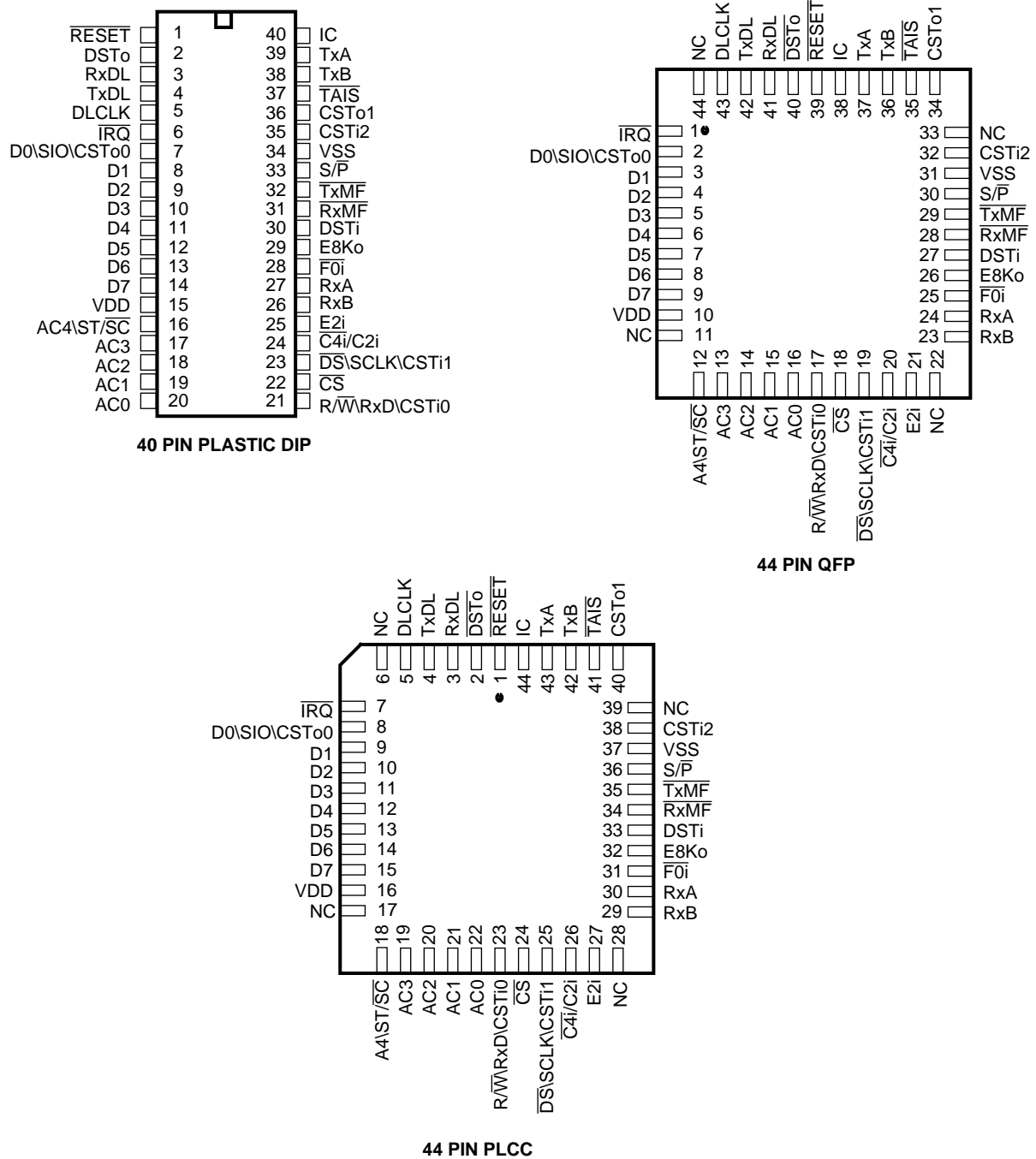

Figure 2 - Pin Connection

## Pin Description

Pin #			Name	Description (see notes 1, 2 and 3)
DIP	PLCC	QFP		
1	1	39	RESET	<b>RESET (Input):</b> Low - maintains the device in a reset condition. High - normal operation. The MT9079 should be reset after power-up. The time constant for a power-up reset circuit (see Figure 11) must be a minimum of five times the rise time of the power supply. In normal operation, the RESET pin must be held low for a minimum of 100 nsec. to reset the device.
2	2	40	DSTo	<b>Data ST-BUS (Output):</b> A 2.048 Mbit/s serial output stream which contains the 30 PCM or data channels received from the PCM 30 line. See Figure 4b.
3	3	41	RxDL	<b>Receive Data Link (Output):</b> A 4 kbit/s serial stream which is demultiplexed from a selected national bit (non-frame alignment signal) of the PCM 30 receive signal. Received DL data is clocked out on the rising edge of DLCLK, see Figure 20.
4	4	42	TxDL	<b>Transmit Data Link (Input):</b> A 4 kbit/s serial stream which is multiplexed into a selected national bit (non-frame alignment signal) of the PCM 30 transmit signal. Transmit DL data is clocked in on the rising edge of internal clock IDCLK, see Figure 21.
5	5	43	DLCLK	<b>Data Link Clock (Output):</b> A 4 kHz clock signal used to clock out DL data (RxDL) on its rising edge. It can also be used to clock DL data in and out of external serial controllers (i.e., MT8952). See TxDL and RxDL pin descriptions.
-	6	44	NC	<b>No Connection.</b>
6	7	1	$\overline{\text{IRQ}}$	<b>Interrupt Request (Output):</b> Low - interrupt request. High - no interrupt request. $\overline{\text{IRQ}}$ is an open drain output that should be connected to $V_{DD}$ through a pull-up resistor. An active $\overline{\text{CS}}$ signal is not required for this pin to function. This pin should be left open when the ST-BUS control port is selected.
7	8	2	D0 [P]  SIO [S]  CSTo0 [ST]	<b>Data 0 (Three-state I/O):</b> The least significant bit of the bidirectional data bus of the parallel processor interface.  <b>Serial Input/Output (Three state I/O):</b> This pin function is used in serial controller mode and can be configured as control data input/output for Intel operation (connect to controller pin RxD). Input data is sampled LSB first on the rising edge of SCLK; data is output LSB first on the falling edge of SCLK. It can also be configured as the control data output for Motorola and National Microwire operation (data output MSB first on the falling edge of SCLK). See $\overline{\text{CS}}$ pin description.  <b>Control ST-BUS Zero (Output):</b> A 2.048 Mbit/s serial status stream which provides device status, performance monitoring, alarm status and phase status data.
8-14	9-15	3-9	D1-D7 [P]	<b>Data 1 to Data 7 (Three-state I/O):</b> These signals, combined with D0, form the bidirectional data bus of the parallel processor interface (D7 is the most significant bit).
15	16	10	$V_{DD}$	<b>Positive Power Supply (Input):</b> +5V $\pm$ 10%.
-	17	11	NC	<b>No Connection.</b>
16	18	12	AC4 [P]  $\text{ST}/\overline{\text{SC}}$ [ST S]	<b>Address/Control 4 (Input):</b> The most significant address and control input for the non-multiplexed parallel processor interface.  <b>ST-BUS/Serial Controller (Input):</b> High - selects ST-BUS mode of operation. Low - selects serial controller mode of operation.
17-20	19-22	13-16	AC3-AC0 [P]	<b>Address/Control 3 to 0 (Inputs):</b> Address and control inputs for the non-multiplexed parallel processor interface. AC0 is the least significant input.

## Pin Description (Continued)

Pin #			Name	Description (see notes 1, 2 and 3)
DIP	PLCC	QFP		
21	23	17	R $\overline{W}$ [P]	<b>Read/Write (Input):</b> High - the parallel processor is reading data from the MT9079. Low - the parallel processor is writing data to the MT9079.
			RxD [S]	<b>Receive Data (Input):</b> This pin function is used in Motorola and National Microwire serial controller mode. Data is sampled on the rising edge of SCLK, MSB first. See $\overline{CS}$ pin description.
			CSTi0 [ST]	<b>Control ST-BUS Zero (Input):</b> A 2.048 Mbit/s serial control stream which contains the device control, mode selection, and performance monitoring control.
22	24	18	$\overline{CS}$ [SP]	<b>Chip Select (Input):</b> Low - selects the MT9079 parallel processor or serial controller interface. High - the parallel processor or serial controller interface is idle and all bus I/O pins will be in a high impedance state. When controller mode is selected, the SCLK input is sampled when $\overline{CS}$ is brought low. If SCLK is high the device is in Intel mode; if SCLK is low it will be in Motorola/National Microwire mode. This pin has no function (NC) in ST-BUS mode.
23	25	19	$\overline{DS}$ [P]	<b>Data Strobe (Input):</b> This input is the active low data strobe of the parallel processor interface.
			SCLK [S]	<b>Serial Clock (Input):</b> This is used in serial controller mode to clock serial data in and out of the MT9079 on RxD and SIO. If SCLK is high when $\overline{CS}$ goes low, the device will be in Intel mode; if SCLK is low when $\overline{CS}$ goes low, it will be in Motorola/National Microwire mode.
			CSTi1 [ST]	<b>Control ST-BUS One (Input):</b> A 2.048 Mbit/s serial control stream which contains the per timeslot control programming.
24	26	20	$\overline{C4i/C2i}$	<b>4.096 MHz and 2.048 MHz System Clock (Input):</b> This is master clock for the serial PCM data and ST-BUS sections of the MT9079. The MT9079 automatically detects whether a 4.096 or 2.048 MHz clock is being used. See Figure 22 for timing information.
25	27	21	E2i	<b>2.048 MHz Extracted Clock (Input):</b> This clock is extracted from the received signal. Its rising edge is used internally to clock in data received on RxA and RxB. See Figure 29.
-	28	22	NC	<b>No Connection.</b>
26	29	23	RxB	<b>Receive B (Input):</b> Received split phase unipolar signal decoded from a bipolar line receiver. Receives RZ and NRZ bipolar signals. See Figures 29 and 31.
27	30	24	RxA	<b>Receive A (Input):</b> Received split phase unipolar signal decoded from a bipolar line receiver. Receives RZ and NRZ bipolar signals. See Figures 29 and 31.
28	31	25	$\overline{F0i}$	<b>Frame Pulse (Input):</b> This is the ST-BUS frame synchronization signal which delimits the 32 channel frame of all ST-BUS streams, as well as DSTi and DSTo in all modes.
29	32	26	E8Ko	<b>Extracted 8 kHz Clock (Output):</b> An 8 kHz signal generated by dividing the extracted 2.048 MHz clock (E2i) by 256 and aligning it with the received PCM 30 frame. The 8 kHz signal can be used to synchronize the system clock with the extracted 2.048 MHz clock. E8Ko is high when 8KSEL=0. See Figure 27.
30	33	27	DSTi	<b>Data ST-BUS (Input).</b> A 2.048 Mbit/s serial stream which contains the 30 PCM or data channels to be transmitted on the PCM 30 line. See Figure 4a.

## Pin Description (Continued)

Pin #			Name	Description (see notes 1, 2 and 3)
DIP	PLCC	QFP		
31	34	28	$\overline{\text{RxMF}}$	<b>Receive Multiframe Boundary (Output):</b> An output pulse delimiting the received multiframe boundary. The next frame output on the data stream (DSTo) is basic frame zero on the PCM 30 link. This receive multiframe signal can be related to either the receive CRC multiframe (MFSEL=1) or the receive signalling multiframe (MFSEL=0). See Figures 25 and 26.
32	35	29	$\overline{\text{TxMF}}$	<b>Transmit Multiframe Boundary (Input):</b> This input is used to set the channel associated and CRC transmit multiframe boundary. The device will generate its own multiframe if this pin is held high. This input is pulled high in most applications. See Figures 24 to 26.
33	36	30	S/ $\overline{\text{P}}$	<b>Serial/Parallel (Input):</b> High - serial controller port or ST-BUS operation. Low - parallel processor port operation.
34	37	31	V <sub>SS</sub>	<b>Negative Power Supply (Input):</b> Ground.
35	38	32	CSTi2	<b>Control ST-BUS Input Two (Input):</b> A 2.048 Mbit/s ST-BUS control stream which contains the 30 (ABCDXXXX) transmit signalling nibbles when RPSIG=0. When RPSIG=1 this pin has no function. Only the most significant nibbles of each ST-BUS timeslot are valid. See Figure 4c.
-	39	33	NC	<b>No Connection.</b>
36	40	34	CSTo1	<b>Control ST-BUS Output One (Output):</b> A 2.048 Mbit/s serial status stream which provides the 30 (ABCDABCD) receive signalling nibbles. See Tables 15 - 17.
37	41	35	$\overline{\text{TAIS}}$	<b>Transmit Alarm Indication Signal (Input):</b> High - TxA and TxB will transmit data normally. Low - TxA and TxB transmits an AIS (all ones signal).
38	42	36	TxB	<b>Transmit B (Output):</b> A split phase unipolar signal suitable for use with TxA, an external line driver and a transformer to construct a bipolar PCM 30 line signal. This output can also transmit RZ and NRZ bipolar signals. See Figures 28 and 30.
39	43	37	TxA	<b>Transmit A (Output):</b> A split phase unipolar signal suitable for use with TxB, an external line driver and a transformer to construct a bipolar PCM 30 line signal. This output can also transmit RZ and NRZ bipolar signals. See Figures 28 and 30.
40	44	38	IC	<b>Internal Connection (Input):</b> Connect to ground for normal operation.

## Notes:

1. All inputs are CMOS with TTL compatible logic levels.
2. All outputs are CMOS and are compatible with both TTL and CMOS logic levels.
3. See AC Electrical Characteristics - Timing Parameter Measurement Voltage Levels for input and output voltage thresholds.

## Functional Description

The MT9079 is an advanced PCM 30 framer that meets or supports the layer 1 CCITT Recommendations of G.703, G.704, G.706, G.775, G.796 and G.732 for PCM 30; I.431 for ISDN Primary Rate; and T1.102 for DS1A. It also meets or supports the layer 1 requirements of ETSI ETS 300 011 and ETS 300 233. Included are all the features of the MT8979, except for the digital attenuation ROM and Alternate Digit Inversion (ADI). It also provides extensive performance monitoring data collection features.

Control of the MT9079 is achieved through the hardware selection of either a parallel non-multiplexed microprocessor port, an Intel or Motorola serial controller port, or an ST-BUS port. The parallel port is based on the signals used by Motorola microprocessors, but it can also be easily mated to Intel microprocessors (see the Applications section of this data sheet).

The serial microcontroller interface of the MT9079 will automatically adapt to either Intel or Motorola signalling. An ST-BUS interface, consisting of two control and one status stream, may also be selected, however, the circular and national bit buffers cannot be accessed in this mode.

The MT9079 supports enhanced features of the MT8979. The receive slip buffer hysteresis has been extended to 26 channels, which is suitable for multiple trunk applications where large amounts of wander tolerance is required. The phase status word has been extended to the one sixteenth bit when the device is clocked with  $\overline{C4}$ . This provides the resolution required for high performance phase locked loops.

The received CAS (Channel Associated Signalling) bits are frozen when signalling multiframe synchronization is lost, and the CAS debounce duration has been extended to be compliant with CCITT Q.422.

The MT9079 framing algorithm has been enhanced to allow automatic interworking between CRC-4 and non-CRC-4 interfaces. Automatic basic frame alarm and multiframe alarms have also been added.

The national bits of the MT9079 can be accessed in three ways. First, through single byte registers; second, through five byte transmit and receive national bit buffers; and third, through the data link pins TxDL, RxDL and DLCLK.

A new feature is the ability to select transparent or termination modes of operation. In termination mode the CRC-4 calculation is performed as part of the framing algorithm. In transparent mode the MT9079 allows the data link maintenance channel to be modified and updates the CRC-4 remainder bits to reflect this new data. All channel, framing and signalling data passes through the device unaltered. This is useful for intermediate point applications of an PCM 30 link where the data link data is modified, but the error information transported by the CRC-4 bits must be passed to the terminating end. See the Application section of this data sheet.

The MT9079 has a comprehensive suite of status, alarm, performance monitoring and reporting features. These include counters for BPVs, CRC errors, E-bit errors, errored frame alignment signals, BERT, and RAI and continuous CRC errors. Also, included are transmission error insertion for BPVs, CRC-4 errors, frame and non-frame alignment signal errors, and loss of signal errors.

Dual transmit and receive 16 byte circular buffers, as well as line code insertion and detection features have been implemented and can be associated with any PCM 30 time slot.

A complete set of loopbacks has been implemented, which include digital, remote, ST-BUS, payload, and local and remote time slot.

The functionality of the MT9079 has been heighten with the addition of a comprehensive set of maskable interrupts and an interrupt vector function. Interrupt sources consist of synchronization status, alarm status, counter indication and overflow, timer status, slip indication, maintenance functions and receive channel associated signalling bit changes.

## The PCM 30 Interface

PCM 30 (E1) basic frames are 256 bits long and are transmitted at a frame repetition rate of 8000 Hz, which results in a aggregate bit rate of 256 bits x 8000/sec. = 2.048 Mbits/sec. The actual bit rate is 2.048 Mbits/sec +/- 50 ppm encoded in  $\overline{HDB3}$  format. Basic frames are divided into 32 time slots numbered 0 to 31, see Figure 32. Each time slot is 8 bits in length and is transmitted most significant bit first (numbered bit 1). This results in a single time slot data rate of 8 bits x 8000/sec. = 64 kbits/sec.

It should be noted that the Mitel ST-BUS also has 32 channels numbered 0 to 31, but the most significant bit of an eight bit channel is numbered bit 7 (see Mitel Application Note MSAN-126). Therefore,

ST-BUS bit 7 is synonymous with PCM 30 bit 1; bit 6 with bit 2: and so on. See Figure 33.

PCM 30 time slot zero is reserved for basic frame alignment, CRC-4 multiframe alignment and the communication of maintenance information. In most configurations time slot 16 is reserved for either channel associated signalling (CAS or ABCD bit signalling) or common channel signalling (CCS). The remaining 30 time slots are called channels and carry either PCM encoded voice frequency signals or digital data signals. Channel alignment and bit numbering is consistent with time slot alignment and bit numbering. However, channels are numbered 1 to 30 and relate to time slots as per Table 1.

PCM 30 Timeslots	0	1 2 3 ....15	16	17 18 19 ....31
Voice/Data Channels	X	1 2 3 ....15	X	16 17 18 ....30

**Table 1 - Time slot to Channel Relationship**

**Basic Frame Alignment**

Time slot zero of every basic frame is reserved for basic frame alignment and contains either a Frame Alignment Signal (FAS) or a Non-frame Alignment Signal (NFAS). FAS and NFAS occur in time slot zero of consecutive basic frames as can be see in Table 4. Bit two is used to distinguish between a FAS (bit two = 0) and a NFAS (bit two = 1).

Basic frame alignment is initiated by a search for the bit sequence 0011011 which appears in the last seven bit positions of the FAS, see Frame Algorithm section. Bit position one of the FAS can be either a CRC-4 remainder bit or an international usage bit.

Bits four to eight of the NFAS (i.e.,  $S_{a4} - S_{a8}$ ) are national bits, which telephone authorities used to communicate maintenance, control and status information. A single national bit can also be used as a 4 KHz maintenance channel or data link. Bit three, the ALM bit, is used to indicate the near end basic frame synchronization status to the far end of a link. Bit position one of the NFAS can be either a CRC-4 multiframe alignment signal, an E-bit or an international usage bit. Refer to an approvals laboratory and national standards bodies for specific requirements.

**CRC-4 Multiframing**

The primary purpose for CRC-4 multiframing is to provide a verification of the current basic frame alignment, although it can be used for other functions

such as bit error rate estimation. The CRC-4 multiframe consists of 16 basic frames numbered 0 to 15, and has a repetition rate of 16 frames X 125 microseconds/frame = 2 msec. CRC-4 multiframe alignment is based on the 001011 bit sequence, which appears in bit position one of the first six NFASs of a CRC-4 multiframe.

The CRC-4 multiframe is divided into two submultiframes, numbered 1 and 2, which are each eight basic frames or 2048 bits in length.

The CRC-4 frame alignment verification functions as follows. Initially, the CRC-4 operation must be activated and CRC-4 multiframe alignment must be achieved at both ends of the link. At the local end of a link all the bits of every transmit submultiframe are passed through a CRC-4 polynomial (multiplied by  $X^4$  then divided by  $X^4 + X + 1$ ), which generates a four bit remainder. This remainder is inserted in bit position one of the four FASs of the following submultiframe before it is transmitted, see Table 4. The submultiframe is then transmitted and at the far end the same process occurs. That is, a CRC-4 remainder is generated for each received submultiframe. These bits are compared with the bits received in position one of the four FASs of the next received submultiframe. This process takes place in both directions of transmission.

When more than 914 CRC-4 errors (out of a possible 1000) are counted in a one second interval, the framing algorithm will force a search for a new basic frame alignment. See Frame Algorithm section for more details.

The result of the comparison of the received CRC-4 remainder with the locally generated remainder will be transported to the near end by the E-bits. Therefore, if  $E_1 = 0$ , a CRC-4 error was discovered in a submultiframe one received at the far end; and if  $E_2 = 0$ , a CRC-4 error was discovered in a submultiframe two received at the far end. No submultiframe sequence numbers or re-transmission capabilities are supported with layer 1 PCM 30 protocol. See CCITT G.704 and G.706 for more details on the operation of CRC-4 and E-bits.

**CAS Signalling Multiframing**

The purpose of the signalling multiframing algorithm is to provide a scheme that will allow the association of a specific ABCD signalling nibble with the appropriate PCM 30 channel. Time slot 16 is reserved for the communication of Channel Associated Signalling (CAS) information (i.e., ABCD signalling bits for up to 30 channels). Refer to CCITT

G.704 and G.732 for more details on CAS multiframing requirements.

A CAS signalling multiframe consists of 16 basic frames (numbered 0 to 15), which results in a multiframe repetition rate of 2 msec. It should be noted that the boundaries of the signalling multiframe may be completely distinct from those of the CRC-4 multiframe. CAS multiframe alignment is based on a multiframe alignment signal (a 0000 bit sequence), which occurs in the most significant nibble of time slot 16 of basic frame zero of the CAS multiframe. Bit 6 of this time slot is the multiframe alarm bit (usually designated Y). When CAS multiframing is acquired on the receive side, the transmit Y-bit is zero; when CAS multiframing is not acquired, the transmit Y-bit is one. Bits 5, 7 and 8 (usually designated X) are spare bits and are normally set to one if not used.

Time slot 16 of the remaining 15 basic frames of the CAS multiframe (i.e., basic frames 1 to 15) are reserved for the ABCD signalling bits for the 30 payload channels. The most significant nibbles are the reserved for channels 1 to 15 and the least significant nibbles are reserved for channels 16 to 30. That is, time slot 16 of basic frame 1 has ABCD for channel 1 and 16, time slot 16 of basic frame 2 has ABCD for channel 2 and 17, through to time slot 16 of basic frame 15 has ABCD for channel 15 and 30.

## MT9079 Access and Control

### The Control Port Interface

The control and status of the MT9079 is achieved through one of three generic interfaces, which are parallel microprocessor, serial microcontroller, and ST-BUS. This control port selection is done through pins  $S/\bar{P}$  and  $ST/\bar{SC}$ .

The parallel microprocessor port ( $S/\bar{P} = 0$  and  $ST/\bar{SC} = AC4$ ) is non-multiplexed and consists of an eight bit bidirectional data bus (D0-D7), a five bit address/command bus (AC0-AC4), read/write ( $R/\bar{W}$ ), chip select ( $\bar{CS}$ ), data strobe ( $\bar{DS}$ ) and an interrupt request ( $\bar{IRQ}$ ). This port can be easily interfaced to most high speed parallel microprocessors.

The serial microcontroller port ( $S/\bar{P} = 1$  and  $ST/\bar{SC} = 0$ ) consists of a receive data input (RxD), serial clock input (SCLK), serial data input/output (SIO), interrupt request ( $\bar{IRQ}$ ), and chip select ( $\bar{CS}$ ). This port will automatically interface to Intel, Motorola or National microcontrollers in either synchronous or asynchronous modes. When controller mode is

selected, the SCLK input is sampled when  $\bar{CS}$  is brought low. If SCLK is high the device is in Intel mode; if SCLK is low it will be in Motorola/National Microwire mode.

The ST-BUS port ( $S/\bar{P} = 1$  and  $ST/\bar{SC} = 1$ ) consists of control streams CSTi0 and CSTi1 and status stream CSTo0. It should be noted that in this mode access to the circular buffers and notional bit buffers is not provided, and the  $\bar{IRQ}$  function is not supported. This port meets the requirements of the "ST-BUS Generic Device Specification", Mitel Application Note MSAN-126.

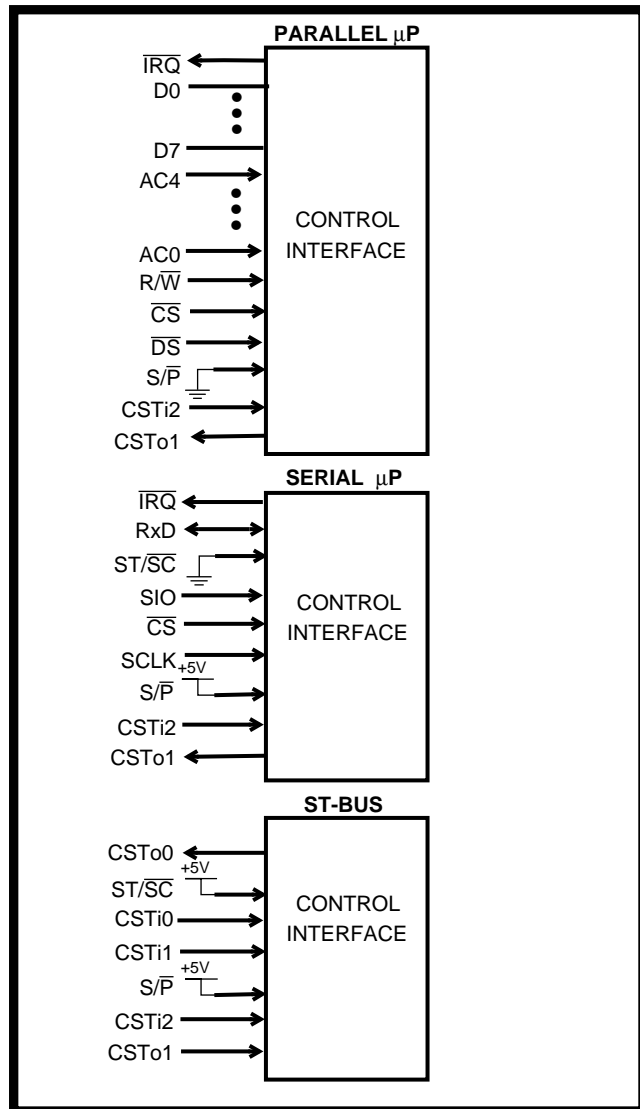

Figure 3 - Control Port Interface

### Control and Status Register Access

The parallel microprocessor and serial microcontroller interfaces gain access to specific registers of the MT9079 through a two step process. First, writing to the Command/Address Register (CAR) selects one of the 14 pages of control and status registers (CAR address: AC4 = 0, AC3-AC0 =



don't care, CAR data D7 - D0 = page number). Second, each page has a maximum of 16 registers that are addressed on a read or write to a non-CAR address (non-CAR: address AC4 = 1, AC3-AC0 = register address, D7-D0 = data). Once a page of memory is selected, it is only necessary to write to the CAR when a different page is to be accessed. See Figure 17 for timing requirements.

Communications between a serial controller and MT9079 is a two byte operations. First, a Command/Address byte selects the address and operation that follows. That is, the R/W bit selects a read or write function and A<sub>4</sub> determines if the next byte is a new memory page address (A<sub>4</sub> = 0) or a data transfer within the current memory page (A<sub>4</sub> = 1). The second byte is either a new memory page address (when A<sub>4</sub> = 0) or a data byte (when A<sub>4</sub> = 1). This is illustrated as follows:

a) Command/Address byte -

R/W	X	X	A <sub>4</sub>	A <sub>3</sub>	A <sub>2</sub>	A <sub>1</sub>	A <sub>0</sub>
-----	---	---	----------------	----------------	----------------	----------------	----------------

where:

- R/W - read or write operation,
- X - no function,
- A<sub>4</sub> = 0 - new memory page address to follow,
- A<sub>4</sub> = 1 - data byte to follow, and
- A<sub>3</sub>-A<sub>0</sub> - determines the byte address.

b) Page address or data byte -

D <sub>7</sub>	D <sub>6</sub>	D <sub>5</sub>	D <sub>4</sub>	D <sub>3</sub>	D <sub>2</sub>	D <sub>1</sub>	D <sub>0</sub>
----------------	----------------	----------------	----------------	----------------	----------------	----------------	----------------

See Figures 18 and 19 for timing requirements.

**Register Access and Locations**

Table 2 associates the MT9079 control and status pages with access and page descriptions, as well as an ST-BUS stream. When ST-BUS access mode is used, each page contains 16 registers that are associated consecutively with the first or second 16 channels of each ST-BUS stream. That is, page 1 register locations 10000 to 11111 appear on CSTi0 time slots 0 to 15, and page 2 register locations 10000 to 11111 appear on CSTi0 time slots 16 to 31. It should be noted that access to the transmit and receive circular buffers is not supported in ST-BUS mode.

**Common ST-BUS Streams**

There are several control and status ST-BUS streams that are common to all modes. CSTo1 contains the received channel associated signalling bits (e.g., CCITT R1 and R2 signalling), and when control bit RPSIG = 0, CSTi2 is used to control the transmit channel associated signalling. DSTi and DSTo contain the transmit and receive voice and digital data. Figures 4a, b and c illustrate the relative

Page Address D <sub>7</sub> - D <sub>0</sub>	Register Description	Processor/ Controller Access	ST-BUS Access
00000001	Master Control	R/W	CSTi0
00000010		R/W	
00000011	Master Status	R	CSTo0
00000100		R/W	
00000101	Per Channel Transmit Signalling	R/W	CSTi2
00000110	Per Channel Receive Signalling	R	CSTo1
00000111	Per Time Slot Control	R/W	CSTi1
00001000		R/W	
00001001	Transmit Circular Buffer Zero	R/W	---
00001010	Transmit Circular Buffer One	R/W	---
00001011	Receive Circular Buffer Zero	R	---
00001100	Receive Circular Buffer One	R	---
00001101	Transmit National Bit Buffer	R/W	---
00001110	Receive National Bit Buffer	R	---

**Table 2 - Register Summary**

channel positions of the ST-BUS and PCM 30 interface. See Tables 13, 14, 16 and 17 for CAS bit positions in CSTo1 and CSTi2.

## Reset Operation (Initialization)

The MT9079 can be reset using the hardware **RESET** pin (see pin description for external reset circuit requirements) or the software reset bit RST (page 1, address 11H). During the reset state, TxA and TxB are low. When the device emerges from its reset state it will begin to function with the default settings described in Table 3.

Function	Status
Port Selection	as per pins S/P & ST/SC
Mode	Termination
Receive G.704 Framing	Activated
ST-BUS Offset	00000000*
Loopbacks	Deactivated
E8Ko	Deactivated
Transmit FAS	C <sub>n</sub> 0011011
Transmit non-FAS	1/S <sub>n</sub> 1111111
Transmit MFAS (CAS)	00001111
Data Link	Deactivated
CRC Interworking	Activated
Code Insert/Detect	Deactivated
Signalling	CAS (CSTi2 & CSTo1)
ABCD Bit Debounce	Deactivated
Interrupts	Interrupt Mask Word Zero unmasked, all others masked; interrupts not suspended
RxMF Output	Signalling Multiframe
Error Insertion	Deactivated
Coding	10*
Tx/Rx Buffers	Deactivated
Counters	Random

**Table 3 - Reset Status**

\*cleared by the **RESET** pin, but not by the RST control bit.

See the Applications section for the MT9079 initialization procedure.

DSTi #	0	1	2	3	4	5	6	7	8	9	10	11	12	13	14	15	16	17	18	19	20	21	22	23	24	25	26	27	28	29	30	31
PCM 30 Timeslot #	1	2	3	4	5	6	7	8	9	10	11	12	13	14	15	16	17	18	19	20	21	22	23	24	25	26	27	28	29	30	31	

**Figure 4a - Relationship between Input DSTi Channels and Transmitted PCM 30 Timeslots**

DSTo	0	1	2	3	4	5	6	7	8	9	10	11	12	13	14	15	16	17	18	19	20	21	22	23	24	25	26	27	28	29	30	31
PCM 30 Timeslot #	0	1	2	3	4	5	6	7	8	9	10	11	12	13	14	15	SIG	17	18	19	20	21	22	23	24	25	26	27	28	29	30	31

**Figure 4b - Relationship between Received PCM 30 Timeslots and Output DSTo Channels**

CSTo1/CSTi2	0	1	2	3	4	5	6	7	8	9	10	11	12	13	14	15	16	17	18	19	20	21	22	23	24	25	26	27	28	29	30	31
PCM 30 Basic Frame Timeslot 16 for channel	0	1	2	3	4	5	6	7	8	9	10	11	12	13	14	15	0	1	2	3	4	5	6	7	8	9	10	11	12	13	14	15
	X	1	2	3	4	5	6	7	8	9	10	11	12	13	14	15	X	16	17	18	19	20	21	22	23	24	25	26	27	28	29	30

**Figure 4c - Relationship between PCM 30 Frames, Channels and CSTo1 Channels**

CCS = denotes Signalling Channel if Common Channel Signalling Mode Selected  
 x = Unused Channel

**TAIS Operation**

The  $\overline{\text{TAIS}}$  (Transmit AIS) pin allows the PRI interface to transmit an all ones signal from the point of power-up without writing to any control registers. After the interface has been initialized normal operation can take place by making  $\overline{\text{TAIS}}$  high.

**National Bit Buffers**

Table 4 shows the contents of the transmit and receive Frame Alignment Signals (FAS) and Non-frame Alignment Signals (NFAS) of time slot zero of a PCM 30 signal. Even numbered frames (CRC Frame # 0, 2, 4, ...) are FASs and odd numbered frames (CRC Frame # 1, 3, 5, ...) are NFASs. The bits of each channel are numbered 1 to 8, with 1 being the most significant and 8 the least significant.

CRC	CRC Frame/Type	PCM 30 Channel Zero							
		1	2	3	4	5	6	7	8
Sub Multi Frame 1	0/FAS	C <sub>1</sub>	0	0	1	1	0	1	1
	1/NFAS	0	1	ALM	S <sub>a4</sub>	S <sub>a5</sub>	S <sub>a6</sub>	S <sub>a7</sub>	S <sub>a8</sub>
	2/FAS	C <sub>2</sub>	0	0	1	1	0	1	1
	3/NFAS	0	1	ALM	S <sub>a4</sub>	S <sub>a5</sub>	S <sub>a6</sub>	S <sub>a7</sub>	S <sub>a8</sub>
	4/FAS	C <sub>3</sub>	0	0	1	1	0	1	1
	5/NFAS	1	1	ALM	S <sub>a4</sub>	S <sub>a5</sub>	S <sub>a6</sub>	S <sub>a7</sub>	S <sub>a8</sub>
	6/FAS	C <sub>4</sub>	0	0	1	1	0	1	1
Sub Multi Frame 2	7/NFAS	0	1	ALM	S <sub>a4</sub>	S <sub>a5</sub>	S <sub>a6</sub>	S <sub>a7</sub>	S <sub>a8</sub>
	8/FAS	C <sub>1</sub>	0	0	1	1	0	1	1
	9/NFAS	1	1	ALM	S <sub>a4</sub>	S <sub>a5</sub>	S <sub>a6</sub>	S <sub>a7</sub>	S <sub>a8</sub>
	10/FAS	C <sub>2</sub>	0	0	1	1	0	1	1
	11/NFAS	1	1	ALM	S <sub>a4</sub>	S <sub>a5</sub>	S <sub>a6</sub>	S <sub>a7</sub>	S <sub>a8</sub>
	12/FAS	C <sub>3</sub>	0	0	1	1	0	1	1
	13/NFAS	E <sub>1</sub>	1	ALM	S <sub>a4</sub>	S <sub>a5</sub>	S <sub>a6</sub>	S <sub>a7</sub>	S <sub>a8</sub>
	14/FAS	C <sub>4</sub>	0	0	1	1	0	1	1
	15/NFAS	E <sub>2</sub>	1	ALM	S <sub>a4</sub>	S <sub>a5</sub>	S <sub>a6</sub>	S <sub>a7</sub>	S <sub>a8</sub>

**Table 4 - FAS and NFAS Structure**

 indicates position of CRC-4 multiframe alignment signal.

Table 5 illustrates the organization of the MT9079 transmit and receive national bit buffers. Each row is an addressable byte of the MT9079 national bit buffer, and each column contains the national bits of an odd numbered frame of each CRC-4 Multiframe.

The transmit and receive national bit buffers are selectable in microprocessor or microcontroller

modes, but cannot be accessed in ST-BUS mode. In ST-BUS mode access to the national bits can be achieved through the Transmit and Receive Non-frame Alignment Signal (CSTi0 and CSTo). When selected, the Data Link (DL) pin functions override the transmit national bit buffer function.

The CALN (CRC-4 Alignment) status bit and maskable interrupt CALNI indicate the beginning of every received CRC-4 multiframe.

Addressable Bytes	Frames 1, 3, 5, 7, 9, 11, 13 & 15 of a CRC-4 Multiframe							
	F1	F3	F5	F7	F9	F11	F13	F15
NBB0	S <sub>a4</sub>	S <sub>a4</sub>	S <sub>a4</sub>	S <sub>a4</sub>	S <sub>a4</sub>	S <sub>a4</sub>	S <sub>a4</sub>	S <sub>a4</sub>
NBB1	S <sub>a5</sub>	S <sub>a5</sub>	S <sub>a5</sub>	S <sub>a5</sub>	S <sub>a5</sub>	S <sub>a5</sub>	S <sub>a5</sub>	S <sub>a5</sub>
NBB2	S <sub>a6</sub>	S <sub>a6</sub>	S <sub>a6</sub>	S <sub>a6</sub>	S <sub>a6</sub>	S <sub>a6</sub>	S <sub>a6</sub>	S <sub>a6</sub>
NBB3	S <sub>a7</sub>	S <sub>a7</sub>	S <sub>a7</sub>	S <sub>a7</sub>	S <sub>a7</sub>	S <sub>a7</sub>	S <sub>a7</sub>	S <sub>a7</sub>
NBB4	S <sub>a8</sub>	S <sub>a8</sub>	S <sub>a8</sub>	S <sub>a8</sub>	S <sub>a8</sub>	S <sub>a8</sub>	S <sub>a8</sub>	S <sub>a8</sub>

**Table 5 - MT9079 National Bit Buffers**

Note: NBB0 - NBB4 are addressable bytes of the MT9079 transmit and receive national bit buffers.

**Data Link Operation**

The MT9079 has a user defined 4 kbit/sec. data link for the transport of maintenance and performance monitoring information across the PCM 30 link. This channel functions using one of the national bits (S<sub>a4</sub>, S<sub>a5</sub>, S<sub>a6</sub>, S<sub>a7</sub> or S<sub>a8</sub>) of the PCM 30 channel zero non-frame alignment signal. The S<sub>a</sub> bit used for the DL is selected by making one of the bits, S<sub>a4</sub> - S<sub>a8</sub>, high in the Data Link Select Word. Access to the DL is provided by pins DLCLK, TxDL and RxDL, which allow easy interfacing to an HDLC controller.

The 4 kHz DLCLK output signal is derived from the ST-BUS clocks and is aligned with the receive data link output RxDL. The DLCLK will not change phase with a received frame slip, but the RxDL data has a 50% chance of being lost or repeated when a slip occurs.

The TxDL input signal is clocked into the MT9079 by the rising edge of an internal 4 kHz clock (e.g., internal data link clock IDCLK). The IDCLK is 180 degrees out of phase with the DLCLK. See Figures 20 and 21 for timing requirements.

## Elastic Buffer

When control bit RDLY=0, the MT9079 has a two frame receive elastic buffer, which absorbs wander and low frequency jitter in multi-trunk applications. The received PCM 30 data (RxA and RxB) is clocked into the elastic buffer with the E2i clock and is clocked out of the elastic buffer with the  $\overline{C4i}/C2i$  clock. The E2i extracted clock is generated from, and is therefore phase-locked with, the receive PCM 30 data. In normal operation, the E2i clock will be phase-locked to the  $\overline{C4i}/C2i$  clock by an external phase locked loop (PLL). Therefore, in a single trunk system the receive data is in phase with the E2i clock, the  $\overline{C4i}/C2i$  clock is phase-locked to the E2i clock, and the read and write positions of the elastic buffer will remain fixed with respect to each other.

In a multi-trunk slave or loop-timed system (i.e., PABX application) a single trunk will be chosen as a network synchronizer, which will function as described in the previous paragraph. The remaining trunks will use the system timing derived from the synchronizer to clock data out of their elastic buffers. Even though the PCM 30 signals from the network are synchronize to each other, due to multiplexing, transmission impairments and route diversity, these signals may jitter or wander with respect to the synchronizer trunk signal. Therefore, the E2i clocks of non-synchronizer trunks may wander with respect to the E2i clock of the synchronizer and the system bus. Network standards state that, within limits, trunk interfaces must be able to receive error-free data in the presence of jitter and wander (refer to network requirements for jitter and wander tolerance). The MT9079 will allow a minimum of 26 channels (208 UI, unit intervals) of wander and low frequency jitter before a frame slip will occur.

The minimum delay through the receive elastic buffer is approximately two channels and the maximum delay is approximately 60 channels (RDLY=0), see Figure 5.

When the  $\overline{C4i}/C2i$  and the E2i clocks are not phase-locked, the rate at which data is being written into the elastic buffer from the PCM 30 side may differ from the rate at which it is being read out onto the ST-BUS. If this situation persists, the delay limits stated in the previous paragraph will be violated and the elastic buffer will perform a controlled frame slip. That is, the buffer pointers will be automatically adjusted so that a full PCM 30 frame is either repeated or lost. All frame slips occur on PCM 30 frame boundaries.

The RSLIP and RSLPD status bits give indication of a slip occurrence and direction. A maskable interrupt  $\overline{SLPI}$  is also provided.

Figure 5 illustrates the relationship between the read and write pointers of the receive elastic buffer. Measuring clockwise from the write pointer, if the read pointer comes within two channels of the write pointer a frame slip will occur, which will put the read pointer 34 channels from the write pointer. Conversely, if the read pointer moves more than 60 channels from the write pointer, a slip will occur, which will put the read pointer 28 channels from the write pointer. This provides a worst case hysteresis of 13 channels peak (26 channels peak-to-peak) or a wander tolerance of 208 UI.

When control bit RDLY=1, the receive elastic buffer becomes one frame long and the controlled slip function is disabled. This is to allow the user to control the receive throughput delay of the MT9079 in one of the following ways:

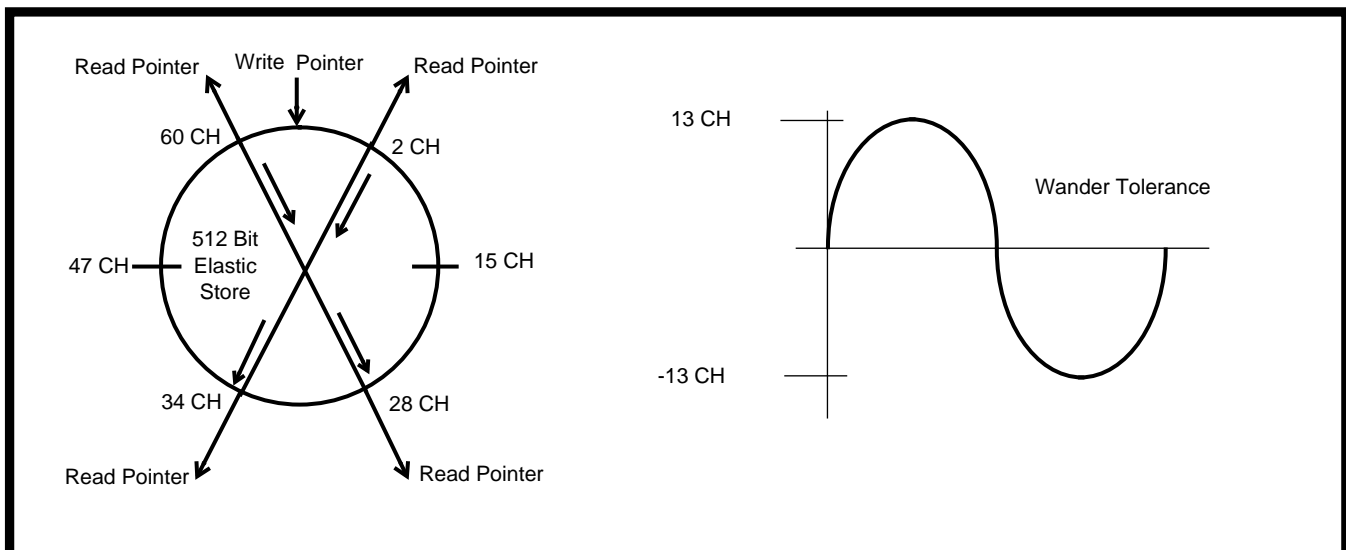

Figure 5 - Elastic Buffer Functional Diagram (208 UI Wander Tolerance)

- 1) by programming the SOFF7-0 bits to select the desired throughput delay, which is indicated by the phase status word bits RxTS4-0 and RxBC2-0.
- 2) by controlling the position of the  $\overline{F0i}$  pulse with respect to the received time slot zero position. The phase status word bits RxTS4-0 and RxBC2-0 will also indicate the delay in this application.

With RDLY=1, the elastic buffer may underflow or overflow. This is indicated by the RSLIP and RSLPD status bits. If RSLPD=0, the elastic buffer has overflowed and a bit was lost; if RSLPD=1, a underflow condition occurred and a bit was repeated.

### Framing Algorithm

The MT9079 contains three distinct, but interdependent, framing algorithms. These algorithms are for basic frame alignment, signalling multiframe alignment and CRC-4 multiframe alignment. Figure 6 is a state diagram that illustrates these functions and how they interact.

After power-up the basic frame alignment framer will search for a frame alignment signal (FAS) in the PCM 30 receive bit stream. Once the FAS is detected, the corresponding bit two of the non-frame alignment signal (NFAS) is checked. If bit two of the NFAS is zero a new search for basic frame alignment is initiated. If bit two of the NFAS is one and the next FAS is correct, the algorithm declares that basic frame synchronization has been found (i.e.,  $\overline{SYNC}$  is low).

Once basic frame alignment is acquired the signalling and CRC-4 multiframe searches will be initiated. The signalling multiframe algorithm will align to the first multiframe alignment signal pattern (MFAS = 0000) it receives in the most significant nibble of channel 16 ( $\overline{MFSYNC} = 0$ ). Signalling multiframe will be lost when two consecutive multiframe are received in error.

The CRC-4 multiframe alignment signal is a 001011 bit sequence that appears in PCM 30 bit position one of the NFAS in frames 1, 3, 5, 7, 9 and 11 (see Table 4). In order to achieved CRC-4 synchronization two consecutive CRC-4 multiframe alignment signals must be received without error (CRCSYN = 0). See Figure 6 for a more detailed description of the framing functions.

The MT9079 framing algorithm supports automatic interworking of interfaces with and without CRC-4 processing capabilities. That is, if an interface with CRC-4 capability, achieves valid basic frame alignment, but does not achieve CRC-4 multiframe alignment by the end of a predefined period, the distant end is considered to be a non-CRC-4 interface. When the distant end is a non-CRC-4 interface, the near end automatically suspends receive CRC-4 functions, continues to transmit CRC-4 data to the distant end with its E-bits set to zero, and provides a status indication. Naturally, if the distant end initially achieves CRC-4 synchronization, CRC-4 processing will be carried out by both ends. This feature is selected when control bit  $\overline{AUTC} = 0$ . See Figure 6 for more details.

Notes for Figure 6:

- 1) The basic frame alignment, signalling multiframe alignment, and CRC-4 multiframe alignment functions operate in parallel and are independent.
- 2) The receive channel associated signalling bits and signalling multiframe alignment bit will be frozen when multiframe alignment is lost.
- 3) Manual re-framing of the receive basic frame alignment and signalling multiframe alignment functions can be performed at any time.
- 4) The transmit RAI bit will be one until basic frame alignment is established, then it will be zero.
- 5) E-bits can be optionally set to zero until the equipment interworking relationship is established. When this has been determined one of the following will take place:
  - a) CRC-to-non-CRC operation - E-bits = 0,
  - b) CRC-to-CRC operation - E-bits as per G.704 and I.431.
- 6) All manual re-frames and new basic frame alignment searches start after the current frame alignment signal position.
- 7) After basic frame alignment has been achieved, loss of frame alignment will occur any time three consecutive incorrect FAS or NFAS are received. Loss of basic frame alignment will reset the complete framing algorithm.

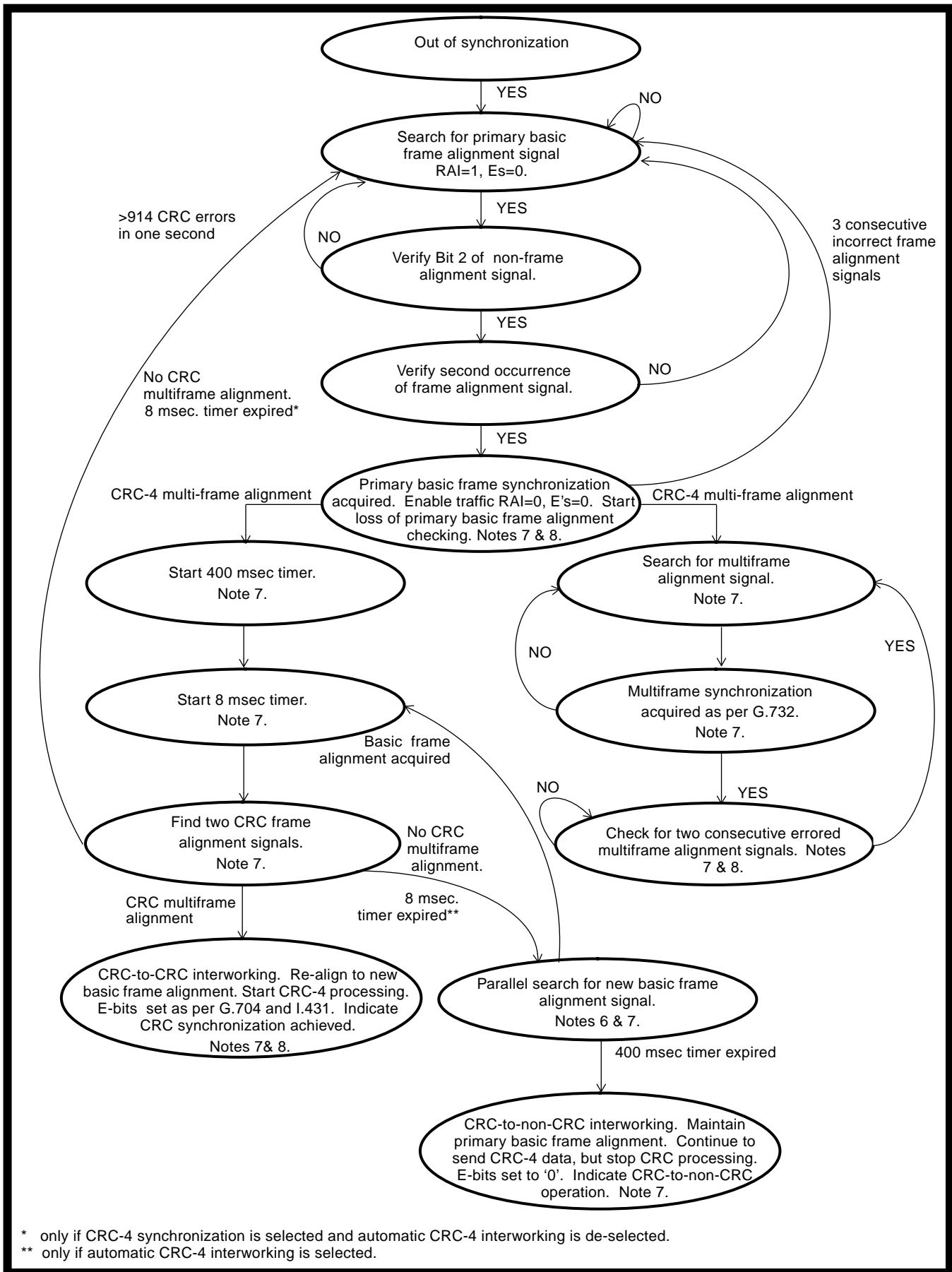

\* only if CRC-4 synchronization is selected and automatic CRC-4 interworking is de-selected.  
 \*\* only if automatic CRC-4 interworking is selected.

Figure 6 - Synchronization State Diagram

8) When CRC-4 multiframing has been achieved, the primary basic frame alignment and resulting multiframe alignment will be adjusted to the basic frame alignment determined during CRC-4 synchronization. Therefore, the primary basic frame alignment will not be updated during the CRC-4 multiframing search, but will be updated when the CRC-4 multiframing search is complete.

**Channel Signalling**

When control bit  $\overline{\text{TxCAS}}$  is low the MT9079 is in Channel Associated Signalling mode (CAS); when  $\overline{\text{TxCAS}}$  is high it is in Common Channel Signalling (CCS) mode. The CAS mode ABCD signalling nibbles can be passed either via the micro-ports (RPSIG = 1) or through related channels of the CSTo1 and CSTi2 serial links (RPSIG = 0), see Figure 4. Memory page five contains the receive ABCD nibbles and page six the transmit ABCD nibbles for micro-port CAS access.

In CAS operation an ABCD signalling bit debounce of 14 msec. can be selected (DBNCE = 1). This is consistent with the signalling recognition time of CCITT Q.422. It should be noted that there may be as much as 2 msec. added to this duration because signalling equipment state changes are not synchronous with the PCM 30 multiframe.

If basic frame synchronization is lost (page 3, address 10H,  $\overline{\text{SYNC}} = 1$ ) all receive CAS signalling nibbles are frozen. Receive CAS nibbles will become unfrozen when basic frame synchronization is acquired.

When the SIGI interrupt is unmasked,  $\overline{\text{IRQ}}$  will become active when a signalling nibble state change is detected in any of the 30 receive channels. The SIGI interrupt mask is located on page 1, address 1CH, bit 0; and the SIGI interrupt vector (page 4, address 12H) is 01H.

**Loopbacks**

In order to meet PRI Layer 1 requirements and to assist in circuit fault sectionalization the MT9079 has six loopback functions. These are as follows:

a) Digital loopback (DSTi to DSTo at the PCM 30 side). Bit DLBK = 0 normal; DLBK = 1 activate.

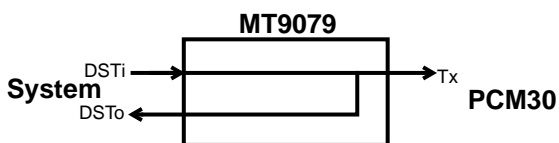

b) Remote loopback (RxA and RxB to TxA and TxB respectively at the PCM 30 side). Bit RLBK = 0 normal; RLBK = 1 activate.

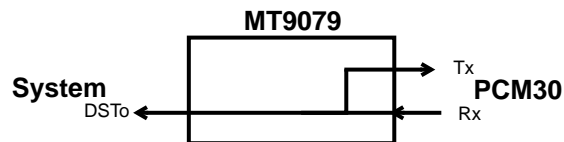

c) ST-BUS loopback (DSTi to DSTo at the system side). Bit SLBK = 0 normal; SLBK = 1 activate.

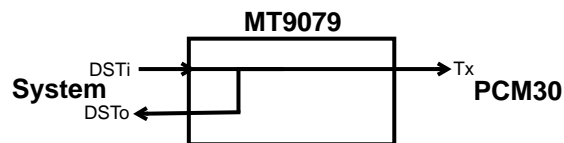

d) Payload loopback (RxA and RxB to TxA and TxB respectively at the system side with FAS and NFAS operating normally). Bit PLBK = 0 normal; PLBK = 1 activate. The payload loopback is effectively a physical connection of DSTo to DSTi within the MT9079. Channel zero and the DL originate at the point of loopback.

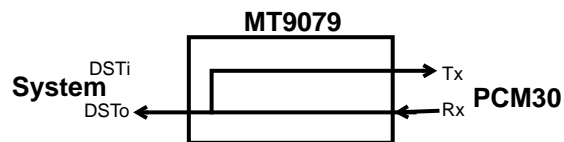

e) Local and remote time slot loopback. Local time slot loopback control bit LTSL = 0 normal; LTSL = 1 activate, will loop around transmit ST-BUS time slots to the DSTo stream. Remote time slot loopback bits RTSL = 0 normal; RTSL = 1 activate, will loop around receive PCM 30 time slots towards the remote PCM 30 end.

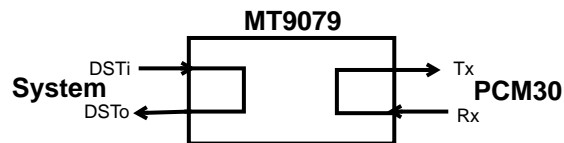

The digital, remote, ST-BUS and payload loopbacks are located on page 1, address 15H, control bits 3 to 0. The remote and local time slot loopbacks are controlled through control bits 4 and 5 of the per time slot control words, pages 7 and 8.

## PCM 30 Interfacing and Encoding

Bits 7 and 6 of page 1, address 15H (COD1-0) determine the PCM 30 format of the PCM 30 transmit and receive signals. The RZ format (COD1-0 = 00) can be used where the line interface is implemented with discrete components. In this case, the pulse width and state of TxA and TxB directly determine the width and state of the PCM 30 pulses.

NRZ format (COD1-0 = 01) is not bipolar, and therefore, only requires a single output line and a single input line (i.e., TxA and RxA). This signal along with a synchronous 4, 8 or 16 MHz clock can interface to a manchester or similar encoder to produce a self-clocking code for a fibre optic transducer.

The NRZB format (default COD1-0 = 10) is used for interfacing to monolithic Line Interface Units (LIUs). With this format pulses are present for the full bit cell, which allows the set-up and hold times to be met easily.

The  $\overline{\text{HDB3}}$  control bit (page 1, address 15H, bit 5) selects either HDB3 encoding or alternate mark inversion (AMI) encoding.

## Performance Monitoring

### MT9079 Error Counters

The MT9079 has six error counters, which can be used for maintenance testing, an ongoing measure of the quality of a PCM 30 link and to assist the designer in meeting specifications such as CCITT I.431 and G.821. In parallel microprocessor and serial microcontroller modes, all counters can be preset or cleared by writing to the appropriate locations. When ST-BUS access is used, this is done by writing the value to be loaded into the counter in the appropriate counter load word (page 2, address 18H to 1FH). The counter is loaded with the new value when the appropriate counter load bit is toggled (page 2, address 15H).

Associated with each counter is a maskable event occurrence interrupt and a maskable counter overflow interrupt. Overflow interrupts are useful when cumulative error counts are being recorded. For example, every time the frame error counter overflow interrupt (FERO) occurs, 256 frame errors have been received since the last FERO interrupt.

### Bit Error Rate Counter (BR7-BR0)

An eight bit Error Rate (BERT) counter BR7 - BR0 is located on page 4 address 18H, and is incremented once for every bit detected in error on either the seven frame alignment signal bits or in a selected channel. When a selected channel is used, the data received in this channel will be compared with the data of the bit error rate compare word CMP7-CMP0. See the explanation of the RBUF1 control bit of the per time slot control words (pages 7 and 8) and the bit error rate compare word (page 2, address 11).

There are two maskable interrupts associated with the bit error rate measurement. BERI is initiated when the least significant bit of the BERT counter (BR0) toggles, and  $\overline{\text{BERO}}$  is initiated when the BERT counter value changes from FFH to 00H.

### Errored Frame Alignment Signal Counter (EFAS7-EFAS0)

An eight bit Frame Alignment Signal Error counter EFAS7 - EFAS0 is located on page 4 address 1AH, and is incremented once for every receive frame alignment signal that contains one or more errors.

There are two maskable interrupts associated with the frame alignment signal error measurement. FER $\overline{\text{I}}$  is initiated when the least significant bit of the errored frame alignment signal counter toggles, and FER0 is initiated when the counter changes from FFH to 00H.

### Bipolar Violation Error Counter (BPV15-BPV0)

The bipolar violation error counter will count bipolar violations or encoding errors that are not part of  $\overline{\text{HDB3}}$  encoding. This counter BPV15-BPV0 is 16 bits long (page 4, addresses 1DH and 1CH) and is incremented once for every BPV error received. It should be noted that when presetting or clearing the BPV error counter, the least significant BPV counter address should be written to before the most significant location.

There are two maskable interrupts associated with the bipolar violation error measurement. BPVI is initiated when the least significant bit of the BPV error counter toggles.  $\overline{\text{BPV0}}$  is initiated when the counter changes from FFFFH to 0000H.



## CRC Error and E-bit Counters

CRC-4 errors and E-bit errors are counted by the MT9079 in order to support compliance with CCITT requirements. These eight bit counters are located on page 4, addresses 1FH and 1EH respectively. They are incremented by single error events, which is a maximum rate of twice per CRC-4 multiframe.

There are two maskable interrupts associated with the CRC error and E-bit error measurement. CRCI and EBI are initiated when the least significant bit of the appropriate counter toggles, and CRCO and EBO are initiated when the appropriate counter changes from FFH to 00H.

### G.821 Bit Error Rate Estimation

A G.821 BERT estimation for an E1 link can be done with either the BERT counter, when it is associated with the FAS, or the Errored Frame Alignment Signal counter. It should be noted that the BERT counter will be incremented once for every bit error found in the FAS, and not just once for every FAS in error. The formula for the link BERT estimation is as follows:

$$BERT\ estimation = BERT\ counter\ value / (N \cdot F \cdot T)$$

where:

*N* is the number of bits verified (i.e., when the FAS is used  $N = 7$ ; when a channel is selected  $N = 8$ ).

*F* is the number of FAS or channels in one second (i.e., when the FAS is used  $F = 4000$ , when a channel is selected  $F = 8000$ ).

*T* is the elapsed time in seconds.

A similar formula can be used with the FAS error counter.

$$BERT\ estimation = FAS\ Error\ counter\ value / (7 \cdot 4000 \cdot T)$$

The CRC-4 error counter can also be used for BERT estimation. The formula for BERT estimation using the CRC-4 error count is as follows:

$$BERT\ estimation = CEt\ counter\ value / (2048000 \cdot T)$$

where:

2048000 is the number of bits that are received in one second.

*T* is the elapsed time in seconds.

A similar formula can be used to provide a BERT estimation of the transmit direction by using the E-bit error counter, EBt.

A more accurate BERT estimation can be done using the Bipolar Violation Error counter. The BPV error counter will count violations that are not due to HDB3 encoding. The formula for this is as follows:

$$BERT\ estimation = BPV\ Error\ counter\ value / (256 \cdot 8000 \cdot T)$$

where:

256 is the number of bits per basic frame.

8000 is the number of basic frames in one second.

*T* is the elapsed time in seconds.

This assumes that one BPV error will be the result of one bit error.

### RAI and Continuous CRC-4 Error Counter

When the receive Remote Alarm Indication is active (RAI = 1 - bit 3 of the NFAS) and a receive E-bit indicates a remote error ( $E_n = 0$ ), the RCRC counter will be incremented. This counter will count the number of submultiframes that were received in error at the remote end of a link during a time when layer one capabilities were lost at that end. This eight bit RCRC counter is located on page 4, addresses 19H.

There are two maskable interrupts associated with the RCRC counter. RCRI is initiated when the least significant bit of the RCRC counter toggles, and RCRO and EBO are initiated when the counter changes from FFH to 00H.

## Maintenance and Alarms

### Error Insertion

Five types of error conditions can be inserted into the transmit PCM 30 data stream through control bits, which are located on page 2, address 10H. These error events include the bipolar violation errors (BPVE), CRC-4 errors (CRCE), FAS errors (FASE), NFAS errors (NFSE), and a loss of signal condition (LOSE). The LOSE function overrides the HDB3 encoding function.

## Circular Buffers

The MT9079 is equipped with two 16 byte circular receive buffers and two 16 byte circular transmit buffers, which can be connected to any PCM 30 time slot. Connection is made through control bits 3 to 0 of the per time slot control words on pages 7 and 8. These buffers will transmit and receive time slot data synchronously with the CRC-4 multiframe.

Transmit circular buffer zero is located on page 9 (TxB0.0 to TxB0.15) and transmit circular buffer one is located on page 10 (TxB1.0 to TxB1.15).

The two circular 16 byte receive buffers (page 11 - RxB0.0 to RxB0.15 and page 12 - RxB1.0 to RxB1.15) record the data received in an associated channel for the next 16 frames beginning with the CRC-4 multiframe boundary. The assigned channel data from the next multiframe will over-write the current data until the buffer is disconnected.

The STOP and START maskable interrupts extend the normal operation of the receive buffers in the following manner.

a) STOP - once activated, receive circular buffer 0 or 1 records time-slot data until that data either matches or mismatches a user-defined eight bit pattern, then the interrupt occurs. This user-defined bit pattern is determined by the Code Detect Word

(CDW) and Detect Word Mask (CDM) mentioned below.

b) START - once activated, receive circular buffer 0 or 1 begins recording time-slot data and initiates an interrupt when a user-defined eight bit pattern is received. This user-defined bit pattern is determined by the Code Detect Word (CDW) and Detect Word Mask (CDM) mentioned below.

The functionality and control of the START and STOP interrupts is described in Table 6.

## PCM 30 Time-Slot Code Insertion and Detection

Idle line codes, flags or user-defined codes can be inserted and detected on any combination of PCM 30 time-slots. This is done as follows:

a) CIW7-0 - Code Insert Word 7 to 0 (page 1, address 17H) is an eight bit code that is transmitted on user-defined PCM 30 time-slots. Transmit time-slots are selected through bit 7 of the per time slot control words (pages 7 and 8).

b) CDW7-0 - Code Detect Word 7 to 0 (page 1, address 18H) is an eight bit code, which is compared with the contents of user-defined PCM 30 receive time-slots. When the contents of the selected channels matches the CDW7-0 the DATA interrupt, if unmasked, will be triggered. Receive time-slots are selected

Interrupt Mask	Function* (note 3)	Description (see notes 1 and 2)
STOP (page 1, address 1EH, bit 2)	STOP0	Circular buffer zero stops recording on a match with CDW and CDM.
	STOP1	Circular buffer one stops recording on a match with CDW and CDM.
	STOP0̄	Circular buffer zero stops recording on a mismatch with CDW and CDM.
	STOP1̄	Circular buffer one stops recording on a mismatch with CDW and CDM.
START (page 1, address 1EH, bit 1)	START0	Circular buffer zero starts recording on a match with CDW and CDM.
	START1	Circular buffer one starts recording on a match with CDW and CDM.
	START0̄	Circular buffer zero starts recording on a mismatch with CDW and CDM.
	START1̄	Circular buffer one starts recording on a mismatch with CDW and CDM.

**Table 6 - START and STOP Interrupt Control**

Notes:

- 1) The interrupt vector value associated with these interrupts is 02H (page 4, address 12H)
- 2) The START and STOP interrupts can be used to record the data between two pre-defined eight bit data patterns received in a particular pattern.
- 3) Circular Buffer Accumulate Control Word (page 2, address 12H).

through bit 6 of the per time slot control words (pages 7 and 8).

c) DWM7-0 - Detect Word Mask 7 to 0 (page 1, address 19H) is an eight bit code, which determines the bits that will be considered in the comparison between the receive data and the Code Detect Word (CDW7-0). If one, the bit position will be included - if zero, the bit position will be excluded.

The DATA interrupt vector value is 02H located on page 4 address 12H.

**Alarms**

The MT9079 will detect and transmit the following alarms:

a) Remote Alarm Indication - bit 3 (ALM) of the receive NFAS;

b) Alarm Indication Signal - unframed all ones signal for at least a double frame (512 bits) or two double frames (1024 bits);

c) Channel 16 AIS - all ones signal in channel 16;

d) Auxiliary pattern - 101010... pattern for at least 512 bits;

e) Loss of Signal - a valid loss of signal condition occurs when there is an absence of receive PCM 30 signal for 255 contiguous pulse (bit) positions from the last received pulse. A loss of signal condition will terminate when an average ones density of at least 12.5% has been received over a period of 255 contiguous pulse positions starting with a pulse; and

f) Remote Signalling Multiframe Alarm - bit 6 (Y-bit) of the multiframe alignment signal.

**Automatic Alarms**

The transmission of RAI and signalling multiframe alarms can be made to function automatically from control bits  $\overline{ARAI}$  and  $\overline{AUTY}$  (page 1, address 11H). When  $\overline{ARAI} = 0$  and basic frame synchronization is lost ( $\overline{SYNC} = 1$ ), the MT9079 will automatically transmit the RAI alarm signal to the far end of the link. The transmission of this alarm signal will cease when basic frame alignment is acquired.

When  $\overline{AUTY} = 0$  and signalling multiframe alignment is not acquired ( $\overline{MFSYNC} = 1$ ), the MT9079 will automatically transmit the multiframe alarm (Y-bit)

signal to the far end of the link. This transmission will cease when signalling multiframe alignment is acquired.

Interrupt Category and Vector	Interrupt Description
<b>Synchronization</b> D7            D0 10000000	$\overline{SYNI}$ - Loss of Synchronization. MFSYI - Loss of Multiframe Sync. CSYNI - Loss of CRC-4 Sync. RFALI - Remote CRC-4 Fail. YI - Remote Multiframe Sync. Fail.
<b>Alarm</b> D7            D0 01000000	$\overline{RAII}$ - Remote Alarm Indication. $\overline{AIS1}$ - Alarm Indication Signal. $\overline{AIS16}$ - AIS on Channel 16. $\overline{LOSI}$ - Loss of Signal. AUXPI - Auxiliary Pattern.
<b>Counter Indication</b> D7            D0 00100000	EBI - Receive E-bit Error. CRCI - CRC-4 Error. CEFI - Consecutive Errored FASs. $\overline{FERI}$ - Frame Alignment Signal Error. BPVI - Bipolar Violation Error. RCRI - RAI and Continuous CRC Error. BERI - Bit Error.
<b>Counter Overflow</b> D7            D0 00010000	EBO - Receive E-bit Error. CRCO - CRC-4 Error. FERO - Frame Alignment Signal. $\overline{BPVO}$ - Bipolar Violation. RCRO - RAI and Continuous CRC Error. BERO - Bit Error
<b>One Second</b> D7            D0 00001000	1SECI - One Second Timer. CALNI - CRC-4 Multiframe Alignment.
<b>SLIP</b> D7            D0 00000100	$\overline{SLPI}$ - Receive Slip.
<b>Maintenance</b> D7            D0 00000010	STOP - Stop Accumulating Data. STRT - Start Accumulating Data. DATA - Data Match.
<b>Signalling</b> D7            D0 00000001	SIGI - Receive Signalling Bit Change.

**Table 7 - MT9079 Interrupt Vectors (IV7-IV0)**

**Interrupts**

The MT9079 has an extensive suite of maskable interrupts, which are divided into eight categories based on the type of event that caused the interrupt. Each interrupt category has an associated interrupt vector described in Table 7. Therefore, when unmasked interrupts occur,  $\overline{IRQ}$  will go low and one or more bits of the interrupt vector (page 4, address 12H) will go high. In processor and controller modes after

# MT9079

the interrupt vector is read it is automatically cleared and  $\overline{\text{IRQ}}$  will return to a high impedance state. The status of the interrupt vector and  $\overline{\text{IRQ}}$  pin is undefined in ST-BUS mode.

All the interrupts of the MT9079 are maskable. This is accomplished through interrupt mask words zero to four, which are located on page 1, addresses 1BH to 1EH.

After a MT9079 reset ( $\overline{\text{RESET}}$  pin or RST control bit) all interrupts of mask words one, two and three are masked; and the interrupts of mask word zero are unmasked.

## Interrupt Mask Word Zero

Bit 7 Bit 0

$\overline{\text{SYNI}}$	$\overline{\text{RAII}}$	$\overline{\text{AISi}}$	$\overline{\text{AIS16i}}$	$\overline{\text{LOSi}}$	$\overline{\text{FERi}}$	$\overline{\text{BPV0}}$	$\overline{\text{SLPI}}$
--------------------------	--------------------------	--------------------------	----------------------------	--------------------------	--------------------------	--------------------------	--------------------------

## Interrupt Mask Word One

Bit 7 Bit 0

EBI	CRCI	CEFI	BPVI	RCRI	BERI	---	SIGI
-----	------	------	------	------	------	-----	------

## Interrupt Mask Word Two

Bit 7 Bit 0

EBO	CRCO	CALNI	FERO	RCRO	BERO	AUXPI	---
-----	------	-------	------	------	------	-------	-----

## Interrupt Mask Word Three

Bit 7 Bit 0

MFSYI	CSYNI	RFALI	YI	1SEC	STOP	STRT	DATA
-------	-------	-------	----	------	------	------	------

All interrupts may be suspended, without changing the interrupt mask words, by making the SPND control bit of page 1, address 1AH high.

## Control and Status Registers

Address (A <sub>4</sub> A <sub>3</sub> A <sub>2</sub> A <sub>1</sub> A <sub>0</sub> )	Register	Function
10H (Table 25)	Multiframe, National Bit Buffer and Data Link Selection	ASEL, MFSEL, NBTB & S <sub>a4</sub> - S <sub>a8</sub>
11H (Table 26)	Mode Selection	TIU0, CRCM, RST, $\overline{\text{ARAI}}$ , AUTY, MODE, CSYN & AUTC
12H (Table 27)	Transmit Non-frame Alignment Signal	TIU1, TALM & TNU4-8
13H (Table 28)	Transmit Multiframe Alignment Signal	TMA1-4, X1, Y, X2 & X3
14H (Table 29)	ST-BUS Offset	SOFF7 - SOFF0
15H (Table 30)	Coding and Loopback Control Word	COD1-0, $\overline{\text{HDB3}}$ , MFRF, DLBK, RLBK, SLBK & PLBK
16H (Table 31)	Transmit Alarm Control	TAIS, TAIS0, TAIS16, TE, REFRM, 8KSEL, CIWA & CDWA
17H (Table 32)	Code Insert Word	CIW7 - CIW0
18H (Table 33)	Code Detect Word	CDW7 - CDW0
19H (Table 34)	Code Detect Bit Mask	DWM7 - DWM0
1AH (Table 35)	Interrupt, Signalling and BERT Control Word	RDLY, SPND, $\overline{\text{TxCAS}}$ , RPSIG & BFAS
1BH (Table 36)	Interrupt Mask Word Zero	$\overline{\text{SYNI}}$ , $\overline{\text{RAII}}$ , $\overline{\text{AISi}}$ , $\overline{\text{AIS16i}}$ , $\overline{\text{LOSi}}$ , $\overline{\text{FERi}}$ , $\overline{\text{BPV0}}$ & $\overline{\text{SLPI}}$
1CH (Table 37)	Interrupt Mask Word One	EBI, CRCI, CEFI, BPVI, RCRI, BERI & SIGI
1DH (Table 38)	Interrupt Mask Word Two	EBO, CRCO, CALNI, FERO, RCRO, BERO & AUXPI
1EH (Table 39)	Interrupt Mask Word Three	MFSYI, CSYNI, RFALI, YI, 1SEC, STOP, STRT & DATA
1FH	Unused.	---

Table 8 - Master Control Words (Page 1)

Address (A <sub>4</sub> A <sub>3</sub> A <sub>2</sub> A <sub>1</sub> A <sub>0</sub> )	Register	Function
10H (Table 40)	Error and Debounce Selection Word	BPVE, CRCE, FASE, NFSE, LOSE & DBNCE
11H (Table 41)	Bit Error Rate Compare Word	CMP7 - CMP0
12H (Table 42)	Circular Buffer Accumulate Control Word	$\overline{\text{START0}}$ , $\overline{\text{START0}}$ , $\overline{\text{START1}}$ , $\overline{\text{START1}}$ , $\overline{\text{STOP0}}$ , $\overline{\text{STOP0}}$ , $\overline{\text{STOP1}}$ & $\overline{\text{STOP1}}$
13H - 14H	Unused.	---
15H (Table 43)	Counter Load Control Word	LDCRC, LDEC, LDBPV, LDEF, LDRC & LDBER
16H - 17H	Unused.	---
18H (Table 44)	Bit Error Rate Load Word	BRLD7 - BRLD0
19H (Table 45)	RAI and Continuous CRC Error Counter Load Word	RCLD7 - RCLD0
1AH (Table 46)	Errored Frame Alignment Load Word	EFLD7 - EFLD0
1BH	Unused.	---
1CH (Table 47)	Most Significant Bipolar Violation Load Word	BPLD15 - BPLD8
1DH (Table 48)	Least Significant Bipolar Violation Load Word	BPLD7 - BPLD0
1EH (Table 49)	E-bit Error Counter Load Word	ECLD7 - ECLD0
1FH (Table 50)	CRC-4 Error Counter Load Word	CCLD7 - CCLD0

Table 9 - Master Control Words (Page 2)

Address (A <sub>4</sub> A <sub>3</sub> A <sub>2</sub> A <sub>1</sub> A <sub>0</sub> )	Register	Function
10H (Table 51)	Synchronization Status Word	$\overline{\text{SYNC}}$ , $\overline{\text{MFSYNC}}$ , $\overline{\text{CRCSYN}}$ , REB1, REB2, CRCRF, PSYNC & CRCIWK
11H (Table 52)	Receive Frame Alignment Signal	RIU0 & RFA2-8
12H (Table 53)	Timer Status Word	1SEC, 2SEC, CRCT, EBT, 400T, 8T & CALN
13H (Table 54)	Receive Non-frame Alignment Signal	RIU1, RNFA2, RALM & RNU4-8
14H (Table 55)	Receive Multiframe Alignment Signal	RMA1-4, X1, Y, X2 & X3
15H (Table 56)	Most Significant Phase Status Word	RSLIP, RSLPD, AUXP, CEFS, RxFRM & RxTS4-2
16H (Table 57)	Least Significant Phase Status Word	RxTS1-0, RxBC2-0 & RxEB2-0
17H - 18H	Unused.	---
19H (Table 58)	Alarm Status Word One	CRCS1, CRCS2, RFAIL, LOSS, AIS16S, AISS, RAIS & RCRS
1AH - 1FH	Unused.	---

Table 10 - Master Status Words (Page 3)

Address (A <sub>4</sub> A <sub>3</sub> A <sub>2</sub> A <sub>1</sub> A <sub>0</sub> )	Register	Function
10H - 11H	Unused.	---
12H (Table 59)	Interrupt Vector	IV7 - IV0
13H - 17H	Unused	---
18H (Table 60)	Bit Error Rate Counter	BR7 - BR0
19H (Table 61)	RAI and Continuous CRC Error Counter	RCRC7 - RCRC0
1AH (Table 62)	Errored Frame Alignment Signal Counter	EFAS7 - EFAS0
1BH	Unused.	---
1CH (Table 63)	Most Significant Bipolar Violation Error Counter	BPV15 - BPV8
1DH (Table 64)	Least Significant Bipolar Violation Error Counter	BPV7 - BPV0
1EH (Table 65)	E-bit Error Counter EBt	EC7 - EC0
1FH (Table 66)	CRC-4 Error Counter CEt	CC7 - CC0

**Table 11 - Master Status Words (Page 4)**

### Per Channel Transmit Signalling (Page 5)

Table 12 describes Page 05H, addresses 10001 to 11111, which contains the Transmit Signalling Control Words for PCM 30 channels 1 to 15 and 16 to 30. Control of these bits is through the processor or controller port when the RPSIG bit is high.

After a  $\overline{\text{RESET}}$  or RST function, this page will be deselected (CSTi2 selected). RPSIG must be made high before the page can be programmed.

Bit	Name	Functional Description
7 - 4	A(n), B(n), C(n) & D(n)	Transmit Signalling Bits for Channel n. These bits are transmitted on the PCM 30 2048 kbit/sec. link in bit positions one to four of time slot 16 in frame n (where n = 1 to 15), and are the A, B, C, D signalling bits associated with channel n.
3 - 0	A(n+15), B(n+15), C(n+15) & D(n+15)	Transmit Signalling Bits for Channel n + 15. These bits are transmitted on the PCM 30 2048 kbit/sec. link in bit positions five to eight of time slot 16 in frame n (where n = 1 to 15), and are the A, B, C, D signalling bits associated with channel n + 15.

**Table 12 - Transmit Channel Associated Signalling (Page 5)**

and Table 14 describes the function of ST-BUS time slots 17 to 31 of CSTi2.

Bit	Name	Functional Description
7 - 4	A(n), B(n), C(n) & D(n)	Transmit Signalling Bits for Channel n. These bits are transmitted on the PCM 30 2048 kbit/sec. link in bit positions one to four of time slot 16 in frame n (where n = 1 to 15), and are the A, B, C, D signalling bits associated with channel n.
3 - 0	---	Unused.

**Table 13 - Transmit CAS Channels 1 to 15 (CSTi2)**

Bit	Name	Functional Description
7 - 4	A(n+15), B(n+15), C(n+15) & D(n+15)	Transmit Signalling Bits for Channel n + 15. These bits are transmitted on the PCM 30 2048 kbit/sec. link in bit positions five to eight of time slot 16 in frame n (where n = 1 to 15), and are the A, B, C, D signalling bits associated with channel n + 15.
3 - 0	---	Unused.

**Table 14 - Transmit CAS Channels 16 to 30 (CSTi2)**

Serial per channel transmit signalling control through CSTi2 is selected when RPSIG is low. Table 13 describes the function of ST-BUS time slots 1 to 15,

**Per Channel Receive Signalling (Page 6)**

Page 06H, addresses 10001 to 11111 contain the Receive Signalling Control Words for PCM 30 channels 1 to 15 and 16 to 30.

Bit	Name	Functional Description
7 - 4	A(n), B(n), C(n) & D(n)	Receive Signalling Bits for Channel n. These bits are received on the PCM 30 2048 kbit/sec. link in bit positions one to four of time slot 16 in frame n (where n = 1 to 15), and are the A, B, C, D signalling bits associated with channel n.
3 - 0	A(n+15), B(n+15), C(n+15) & D(n+15)	Receive Signalling Bits for Channel n + 15. These bits are received on the PCM 30 2048 kbit/sec. link in bit positions five to eight of time slot 16 in frame n (where n = 1 to 15), and are the A, B, C, D signalling bits associated with channel n + 15.

**Table 15 - Receive Channel Associated Signalling (Page 6)**

Serial per channel receive signalling status bits appear on ST-BUS stream CSTo1. Table 16 describes the function of ST-BUS time slots 1 to 15, and Table 17 describes the function of ST-BUS time slots 17 to 31 of CSTo1.

Bit	Name	Functional Description
7 - 4	A(n), B(n), C(n) & D(n)	Receive Signalling Bits for Channel n. These bits are received on the PCM 30 2048 kbit/sec. link in bit positions one to eight of time slot 16 in frame n (where n = 1 to 15), and are the A, B, C, D signalling bits associated with channel n.
3 - 0	---	Same as bits 7-4.

**Table 16 - Receive CAS Channels 1 to 15 (CSTo1)**

Bit	Name	Functional Description
7 - 4	A(n+15), B(n+15), C(n+15) & D(n+15)	Receive Signalling Bits for Channel n + 15. These bits are received on the PCM 30 2048 kbit/sec. link in bit positions five to eight of time slot 16 in frame n (where n = 1 to 15), and are the A, B, C, D signalling bits associated with channel n + 15.
3 - 0	---	Same as bits 7-4.

**Table 17 - Receive CAS Channels 17 to 31 (CSTo1)**

**Per Time Slot Control Words (Pages 7 and 8)**

The control functions described by Table 18 are repeated for each ST-BUS time slot. When ST-BUS access is selected, the programmed CSTi1 time slot corresponds to the controlled ST-BUS or PCM 30 time slot. It should be noted that the two receive and two transmit circular buffers are not accessible in ST-BUS mode.

In processor and controller modes, pages 7 and 8 contain the 32 per time slot control words. Page 7 addresses 10000 to 11111 correspond to time slots 0 to 15, while page 8 addresses 10000 to 11111 correspond to time slots 16 to 31. These control bits are not cleared by the  $\overline{\text{RESET}}$  or RST reset functions.

Bit	Name	Functional Description
7	CDIN	Code Insert Activation. If one, the data of CIW7-0 is transmitted in the corresponding PCM 30 time slot. If zero, the data on DSTi is transmitted on the corresponding PCM 30 time slot.
6	CDDTC	Code Detect Activation. If one, the data received on the corresponding PCM 30 time slot is compared with the unmasked bits of the code detect word. When the DATA interrupt is unmasked and this positive match is made, an interrupt will be initiated. If zero, the data is not be compared to the unmasked bits of the code detect word.
5	RTSL	Remote Time Slot Loopback. If one, the corresponding PCM 30 receive time slot is looped to the corresponding PCM 30 transmit time slot. This received time slot will also be present on DSTo. An ST-BUS offset may force a single frame delay. If zero, the loopback is disabled.
4	LTSL	Local Time Slot Loopback. If one, the corresponding transmit time slot is looped to the corresponding receive time slot. This transmit time slot will also be present on the transmit PCM 30 stream. An ST-BUS offset may force a single frame delay. If zero, this loopback is disabled.

**Table 18 - Per Time Slot Control Words (Pages 7 and 8) (continued)**

Bit	Name	Functional Description
3	TBUF0	Transmit Buffer Zero Connect. If one, the contents of the transmit circular buffer zero will be transmitted in the corresponding time slot beginning at the next multiframe boundary. If zero, circular buffer zero is not connected to this time slot. This buffer is accessible only in processor and controller modes.
2	TBUF1	Transmit Buffer One Connect. If one, the contents of the transmit circular buffer one will be transmitted in the corresponding time slot beginning at the next multiframe boundary. If zero, circular buffer one is not connected to this time slot. This buffer is accessible only in processor and controller modes.
1	RBUF0	Receive Buffer Zero Connect. If one, the data of the corresponding receive time slot will be recorded in receive circular buffer zero beginning at the next multiframe boundary. If zero, circular buffer zero is not connected to this time slot. This buffer is accessible only in processor and controller modes.
0	RBUF1	Receive Buffer One Connect. If one, the data of the corresponding receive time slot will be recorded in receive circular buffer one beginning at the next multiframe boundary. If zero, circular buffer one will not connected to this time slot. This buffer is accessible only in processor and controller modes.

**Table 18 - Per Time Slot Control Words (Pages 7 and 8) (continued)**

### Transmit Circular Buffers One and Zero (Pages 9 and A)

Page 09H, addresses 10000 to 11111 contain the 16 bytes of transmit circular buffer zero (TxB0.0 to TxB0.15 respectively). This feature is functional only in processor and controller modes.

The transmit circular buffers are not cleared by the RST function, nor are they cleared by the RESET function.

Bit	Name	Functional Description
7 - 0	TxB0.n .7 - TxB0.n .0	Transmit Bits 7 to 0. This byte is transmitted on a time slot selected by the TBUF0 bit of the appropriate per time slot control word. n = 0 to 15 and represents a byte position in Transmit Circular Buffer zero (TxB0).

**Table 19 - Transmit Circular Buffer Zero (Page 9)**

Page 0AH, addresses 10000 to 11111 contain the 16 bytes of transmit circular buffer one (TxB1.0 to TxB1.15 respectively). This feature is functional only in processor and controller modes.

Bit	Name	Functional Description
7 - 0	TxB1.n .7 - TxB1.n .0	Transmit Bits 7 to 0. This byte is transmitted on a time slot selected by the TBUF1 bit of the appropriate per time slot control word. n = 0 to 15 and represents a byte position in Transmit Circular Buffer zero (TxB1).

**Table 20 - Transmit Circular Buffer One (Page A)**

### Receive Circular Buffers One and Zero (Pages B and C)

Page 0BH, addresses 10000 to 11111 contain the 16 bytes of receive circular buffer zero (RxB0.0 to RxB0.15 respectively). This feature is functional only in processor and controller modes.

Bit	Name	Functional Description
7 - 0	RxB0.n .7 - RxB0.n .0	Receive Bits 7 to 0. This byte is received from a time slot selected by the RBUF0 bit of the appropriate per time slot control words. n = 0 to 15 and represents a byte position in receive circular buffer zero (RxB0).

**Table 21 - Receive Circular Buffer Zero (Page B)**

Page 0CH, addresses 10000 to 11111 contain the 16 bytes of receive circular buffer one (RxB1.0 to RxB1.15 respectively). This feature is functional only in processor and controller modes.

Bit	Name	Functional Description
7 - 0	RxB1.n .7 - RxB1.n .0	Receive Bits 7 to 0. This byte is received from a time slot selected by the RBUF1 bit of the appropriate per time slot control words. n = 0 to 15 and represents a byte position in receive circular buffer one (RxB1).

**Table 22 - Receive Circular Buffer One (Page C)**



**Transmit National Bit Buffer (Page D)**

Page 0DH, addresses 10000 to 10100 contain the five bytes of the transmit national bit buffer (TNBB0 - TNBB4 respectively). This feature is functional only in processor and controller modes when control bit NBTB=1.

The transmit national bit buffer is not cleared by the RST function, but is cleared by the  $\overline{\text{RESET}}$  function.

Bit	Name	Functional Description
7 - 0	TNBBn.F1 - TNBBn.F15	Transmit $S_{an+4}$ Bits Frames 1 to 15. This byte contains the bits transmitted in bit position n+4 of channel zero of frames 1, 3, 5, 7, 9, 11, 13 and 15 when CRC-4 multiframe alignment is used, or of consecutive odd frames when CRC-4 multiframe alignment is not used. n = 0 to 4 inclusive and corresponds to a byte of the receive national bit buffer.

**Table 23 - Transmit National Bit Buffer Bytes Zero to Four (Page D)**

**Receive National Bit Buffer (Page E)**

Page 0EH, addresses 10000 to 10100 contain the five bytes of the receive national bit buffer (RNBB0 - RNBB4 respectively). This feature is functional only in processor and controller modes.

Bit	Name	Functional Description
7 - 0	RNBBn.F1 - RNBBn.F15	Receive $S_{an+4}$ Bits Frames 1 to 15. This byte contains the bits received in bit position n+4 of channel zero of frames 1, 3, 5, 7, 9, 11, 13 and 15 when CRC-4 multiframe alignment is used, or of consecutive odd frames when CRC-4 multiframe alignment is not used. n = 0 to 4 inclusive and corresponds to a byte of the receive national bit buffer.

**Table 24 - Receive National Bit Buffer Bytes Zero to Four (Page E)**

**Control Page 1**

Tables 25 to 39 describe the bit functions of the page 1 control registers. ( ) in the "Name" column of these tables indicates the state of the control bit after a RESET or RST function.

Bit	Name	Functional Description
7	ASEL (0)	AIS Select. This bit selects the criteria on which the detection of a valid Alarm Indication Signal (AIS) is based. If zero, the criteria is less than three zeros in a two frame period (512 bits). If one, the criteria is less than three zeros in each of two consecutive double-frame periods (512 bits per double-frame).
6	MFSEL (0)	Multiframe Select. This bit determines which receive multiframe signal (CRC-4 or signalling) the $\overline{\text{RxMF}}$ signal is aligned with. If zero, $\overline{\text{RxMF}}$ is aligned with the receive signalling multiframe. If one, the $\overline{\text{RxMF}}$ is aligned with the receive CRC-4 multiframe.
5	NBTB (0)	National Bit Transmit Buffer. When one, the transmit NFAS signal originates from the transmit national bit buffer; when zero, the transmit NFAS signal originates from the TNU4-8 bits of page 1, address 12H.
4 - 0	Sa4 - Sa8 (00000)	A one selects the bits of the non-frame alignment signal for a 4 kbits/sec. data link channel. Data link (DL) selection will function in termination mode only; in transparent mode Sa4 is automatically selected - see MODE control bit of page 1, address 11H. If zero, the corresponding bits of transmit non-frame alignment signal are programmed by the non-frame alignment control word.

**Table 25 - Multiframe, National Bit Buffer and DL Selection Word (Page 1, Address 10H)**

Bit	Name	Functional Description
7	TIU0 (0)	Transmit International Use Zero. When CRC-4 operation is disabled, this bit is transmitted on the PCM 30 2048 kbit/sec. link in bit position one of time-slot zero of frame-alignment frames. It is reserved for international use and should normally be kept at one. If CRC processing is used, this bit is ignored.
6	CRCM (0)	CRC-4 Modification. If one, activates the CRC-4 remainder modification function when the device is in transparent mode. The received CRC-4 remainder is modified to reflect only the changes in the transmit DL. If zero, time slot zero data from DSTi will not be modified in transparent mode.
5	RST (0)*	Reset. When this bit is changed from low to high the MT9079 will reset to its default mode. See the Reset Operation section.
4	ARAI (0)	Automatic RAI Operation. If zero, the Remote Alarm Indication bit will function automatically. That is, RAI = 0 when basic synchronization has been acquired, and RAI = 1 when basic synchronization has not been acquired. If one, the remote alarm indication bit is controlled through the TALM bit of the transmit non-frame alignment control word.
3	AUTY (0)	Automatic Y-Bit Operation. If zero, the Y-bit of the transmit multiframe alignment signal will report the multiframe alignment status to the far end i.e., zero - multiframe alignment acquired, one - lost. If one, the Y-bit is under the manual control of the transmit multiframe alignment control word.
2	MODE (0)	Transmit Mode. If one, the MT9079 is in transparent mode. If zero, it is in termination mode.
1	CSYN (0)	CRC-4 Synchronization. If zero, basic CRC-4 synchronization processing is activated, and TIU0 bit and TIU1 bit (frames 13 and 15) programming will be overwritten. If one, CSYN is disabled, the transmit CRC bits are programmed by TIU0 and the transmit E-bits are programmed by either TxB0, TxB1 or TIU1.
0	AUTC (0)	Automatic CRC-interworking. If zero, automatic CRC-interworking is activated. If one, it is deactivated. See Framing Algorithm section.

**Table 26 - Mode Selection Control Word  
(Page 1, Address 11H)**

Bit	Name	Functional Description
7	TIU1 (1)	Transmit International Use One. When CRC-4 synchronization is disabled, and TxB0 and TxB1 are not connected to channel zero, this bit is transmitted on the PCM 30 2048 kbit/sec. link in bit position one of time slot zero of non-frame alignment frames (international use bit). If CRC-4 synchronization is enabled or TxB0 or TxB1 are connected to time slot zero, this bit is ignored.
6	---	Unused.
5	TALM (0)	Transmit Alarm. This bit is transmitted on the PCM 30 2048 kbit/sec. link in bit position three of time slot zero of non-frame alignment frames. It is used to signal an alarm to the remote end of the PCM 30 link (one - alarm, zero - normal). This control bit is ignored when ARAI is zero (page 1, address 11H).
4 - 0	TNU4-8 (11111)	Transmit National Use Four to Eight. These bits are transmitted on the PCM 30 2048 kbit/sec. link in bit positions four to eight of time slot zero of non-frame alignment frame. See Sa4 - Sa8 control bits of the DL selection word (page 1, address 10H).

**Table 27 - TNFA Control Word  
(Page 1, Address 12H)**

*\* Not affected by the RST function - the state shown in ( ) can be achieved by using the RESET function.*

Bit	Name	Functional Description
7 - 4	TMA1-4 (0000)	Transmit Multiframe Alignment Bits One to Four. These bits are transmitted on the PCM 30 2048 kbit/sec. link in bit positions one to four of time slot 16 of frame zero of every signalling multiframe. These bits are used by the far end to identify specific frames of a signalling multiframe. TMA1-4 = 0000 for normal operation.
3	X1 (1)	This bit is transmitted on the PCM 30 2048 kbit/sec. link in bit position five of time slot 16 of frame zero of every multiframe. This bit is normally set to one.
2	Y (1)	This bit is transmitted on the PCM 30 2048 kbit/sec. link in bit position six of time slot 16 of frame zero of every multiframe. It is used to indicate the loss of multiframe alignment to the remote end of the link. If one - loss of multiframe alignment; if zero - multiframe alignment acquired. This bit is ignored when AUTY is zero (page 1, address 11H).
1 - 0	X2, X3 (1 1)	These bits are transmitted on the PCM 30 2048 kbit/sec. link in bit positions seven and eight respectively, of time slot 16 of frame zero of every multiframe. These bit are normally set to one.

**Table 28 - Transmit MF Alignment Signal  
(Page 1, Address 13H)**

Bit	Name	Functional Description
7 - 0	SOFF7 - SOFF0 (00H)*	ST-BUS Offset Control. This register controls the offset, in bits, between the input and output ST-BUS control and data streams. The input streams are always aligned with F0i and the output streams may be delayed by as much as 255 bits.

**Table 29 - ST-BUS Offset Control Word  
(Page 1, Address 14H)**

Bit	Name	Functional Description										
7 - 6	COD1-0 (1 0)*	These two coding select bits determine the transmit and receive coding options as follows:  <table border="0"> <tr> <td><b>Bits</b></td> <td><b>Function</b></td> </tr> <tr> <td>00</td> <td>RZ (Return to Zero)</td> </tr> <tr> <td>01</td> <td>NRZ (Non-return to Zero)</td> </tr> <tr> <td>10</td> <td>NRZB (Non-return to Zero Bipolar)</td> </tr> <tr> <td>11</td> <td>no function</td> </tr> </table>	<b>Bits</b>	<b>Function</b>	00	RZ (Return to Zero)	01	NRZ (Non-return to Zero)	10	NRZB (Non-return to Zero Bipolar)	11	no function
<b>Bits</b>	<b>Function</b>											
00	RZ (Return to Zero)											
01	NRZ (Non-return to Zero)											
10	NRZB (Non-return to Zero Bipolar)											
11	no function											
5	HDB3 (0)*	High Density Bipolar 3 Selection. If zero, HDB3 encoding is enabled in the transmit direction. If one, AMI without HDB3 encoding is transmitted. HDB3 is always decoded in the receive direction.										
4	MFRF (0)*	Multiframe Reframe. If set, for at least one frame, and then cleared the MT9079 will initiate a search for a new signalling multiframe position. This function is activated on the one-to-zero transition of the MFRF bit.										
3	DLBK (0)	Digital Loopback. If one, then all time slots of DSTi are connected to DSTo on the PCM 30 side of the MT9079. If zero, this feature is disabled. See Loopbacks section.										
2	RLBK (0)	Remote Loopback. If one, then all time slots received on RxA/RxB are connected to TxA/TxB on the PCM 30 side of the MT9079. If zero, then this feature is disabled. See Loopbacks section.										
1	SLBK (0)	ST-BUS Loopback. If one, then all time slots of DSTi are connected to DSTo on the ST-BUS side of the MT9079. If zero, then this feature is disabled. See Loopbacks section.										
0	PLBK (0)	Payload Loopback. If one, then all time slots received on RxA/RxB are connected to TxA/TxB on the ST-BUS side of the MT9079 (this excludes time slot zero). If zero, then this feature is disabled. See Loopbacks section.										

**Table 30 - Coding and Loopback Control Word  
(Page 1, Address 15H)**

\* Not affected by the RST function - the state shown in ( ) can be achieved by using the RESET function.

Bit	Name	Functional Description
7	TAIS (0)	Transmit Alarm Indication Signal. If one, an all ones signal is transmitted in all time slots except zero and 16. If zero, these time slots function normally.
6	TAIS0 (0)	Transmit Alarm Indication Signal Zero. If one, an all ones signal is transmitted in time slot zero. If zero, time slot zero functions normally.
5	TAIS16 (0)	Transmit Alarm Indication Signal 16. If one, an all ones signal is transmitted in time slot 16. If zero, time slot functions normally.
4	TE (0)	Transmit E bits. When CRC-4 synchronization is achieved, the E-bits transmit the received CRC-4 comparison results to the distant end of the link, as per G.704. When zero and CRC-4 synchronization is lost, the transmit E-bits will be zero (NT application). If one and CRC-4 synchronization is lost, the transmit E-bits will be one (TE application).
3	REFRM (0)	Reframe. If one, for at least one frame, and then cleared the device will initiate a search for a new basic frame position. This function is activated on the one-to-zero transition of the REFRM bit.
2	8KSEL (0)	8 kHz Select. If one, an 8 KHz signal synchronized to the received 2048 kbit/sec. signal is output on pin E8Ko. If zero, then E8Ko will be high.
1	CIWA (0)	Code Insert Word Activate. If one, the bit pattern defined by the Code Insert Word is inserted in the transmit time slots defined by the per time slot time slot words. If zero, then this feature is de-activated.
0	CDWA (0)	Code Detect Word Activate. A zero-to-one transition will arm the CDWA function. Once armed the device will search the time slots defined by the per time slot control word for a match with the bit pattern defined by the code detect word. After a match is found the CDWA function must be rearmed before further word detections can be made. If zero, this feature is de-activated.

**Table 31 - Transmit Alarm Control Word  
(Page 1, Address 16H)**

Bit	Name	Functional Description
7 - 0	CIW7 - CIW0 (00H)	Code Insert Word 7 to 0. CIW7 is the most significant bit and CIW0 is the least significant bit of a code word that can be transmitted continuously on any combination of time slots. The time slots which have data replaced by CIW7 to CIW0 are determined by the CDIN bit of the per time slot control word.

**Table 32 - Code Insert Word  
(Page 1, Address 17H)**

Bit	Name	Functional Description
7 - 0	CDW7 - CDW0 (00H)	Code Detect Word 7 to 0. CDW7 is the most significant bit and CDW0 is the least significant bit of a bit pattern that is compared with bit patterns of selected receive time slots. Time slots are selected for comparison by the CDDTC bit of the per time slot control word. If a match is found a maskable interrupt (Data) can be initiated.

**Table 33 - Code Detect Word  
(Page 1, Address 18H)**

Bit	Name	Functional Description
7 - 0	DWM7 - DWM0 (00H)	Detect Word Mask. If one, the corresponding bit position is considered in the comparison between the receive code detect word (CDW) bits and the selected receive time slot bit pattern. If zero, the corresponding bit is excluded from the comparison.

**Table 34 - Receive Code Detect Bit Mask  
(Address 19H)**

Bit	Name	Functional Description
7	RDLY (0)	Receive Delay. If one, the receive elastic buffer will be one frame in length and controlled frame slips will not occur. The RSLIP and RSLPD status bit will indicate a buffer underflow or overflow. If zero, the two frame receive elastic buffer and controlled slip functions are activated.
6	SPND (0)	Suspend Interrupts. If one, the $\overline{IRQ}$ output will be in a high-impedance state and all interrupts will be ignored. If zero, the $\overline{IRQ}$ output will function normally.
5	---	Unused.
4	$\overline{TxCAS}$ (0)	Transmit Channel Associated Signalling. If zero, the transmit section of the device is in CAS mode. If one, it is in common channel signalling mode.
3	RPSIG (0)	Register Programmed Signalling. If one, the transmit CAS signalling will be controlled by programming page 5. If zero, the transmit CAS signalling will be controlled through the CSTi2 stream. This bit has no function in ST-BUS mode.
2	BFAS (0)	Bit Error Count on Frame Alignment Signal. If zero, individual errors in bits 2 to 8 of the receive FAS will increment the Bit Error Rate Counter (BERC). If one, bit errors in the comparison between receive circular buffer one and the bit error rate compare word will be counted.
1 - 0	---	Unused.

**Table 35 - Interrupt, Signalling and BERT Control Word**  
(Page 1, Address 1AH)

Bit	Name	Functional Description
7	$\overline{SYNI}$ (0)	Synchronization Interrupt. When unmasked an interrupt is initiated when a loss of basic frame synchronization condition exists. If 0 - unmasked, 1 - masked. Interrupt vector = 10000000.
6	$\overline{RAII}$ (0)	Remote Alarm Indication Interrupt. When unmasked a received RAI will initiate an interrupt. If 0 - unmasked, 1 - masked. Interrupt vector = 01000000.
5	$\overline{AISi}$ (0)	Alarm Indication Signal Interrupt. When unmasked a received AIS will initiate an interrupt. If 0 - unmasked, 1 - masked. Interrupt vector = 01000000.
4	$\overline{AIS16i}$ (0)	Channel 16 Alarm Indication Signal Interrupt. When unmasked a received AIS16 will initiate an interrupt. If 0 - unmasked, 1 - masked. Interrupt vector = 01000000.
3	$\overline{LOSI}$ (0)	Loss of Signal Interrupt. When unmasked an interrupt is initiated when a loss of signal condition exists. If 0 - unmasked, 1 - masked. Interrupt vector = 01000000.
2	$\overline{FERI}$ (0)	Frame Error Interrupt. When unmasked an interrupt is initiated when an error in the frame alignment signal occurs. If 0 - unmasked, 1 - masked. Interrupt vector = 00100000.
1	$\overline{BPVO}$ (0)	Bipolar Violation Counter Overflow Interrupt. When unmasked an interrupt is initiated when the bipolar violation error counter changes from FFFFH to 0H. If 0 - unmasked, 1 - masked. Interrupt vector = 00010000.
0	$\overline{SLPI}$ (0)	SLIP Interrupt. When unmasked an interrupt is initiated when a controlled frame slip occurs. If 0 - unmasked, 1 - masked. Interrupt vector = 00000100.

**Table 36 - Interrupt Mask Word Zero**  
(Page 1, Address 1BH)

Bit	Name	Functional Description
7	EBI (0)	Receive E-bit Interrupt. When unmasked an interrupt is initiated when a receive E-bit indicates a remote CRC-4 error. 1 - unmasked, 0 - masked. Interrupt vector = 00100000.
6	CRCI (0)	CRC-4 Error Interrupt. When unmasked an interrupt is initiated when a local CRC-4 error occurs. 1 - unmasked, 0 - masked. Interrupt vector = 00100000.
5	CEFI (0)	Consecutively Errored FASs Interrupt. When unmasked an interrupt is initiated when two consecutive errored frame alignment signals are received. 1 - unmasked, 0 - masked. Interrupt vector = 00100000.
4	BPVI (0)	Bipolar Violation Interrupt. When unmasked an interrupt is initiated when a bipolar violation error occurs. 1 - unmasked, 0 - masked. Interrupt vector = 00100000.
3	RCRI (0)	RAI and Continuous CRC Error Interrupt. When unmasked an interrupt is initiated when the RAI and continuous CRC error counter is incremented. 1 - unmasked, 0 - masked. Interrupt vector = 00100000.
2	BERI (0)	Bit Error Interrupt. When unmasked an interrupt is initiated when a bit error occurs. 1 - unmasked, 0 - masked. Interrupt vector = 00100000.
1	---	Unused.
0	SIGI (0)	Signalling (CAS) Interrupt. When unmasked and any of the receive ABCD bits of any channel changes state an interrupt is initiated. 1 - unmasked, 0 - masked. Interrupt vector = 00000001

**Table 37 - Interrupt Mask Word One  
(Page 1, Address 1CH)**

Bit	Name	Functional Description
7	EBO (0)	Receive E-bit Counter Overflow Interrupt. When unmasked an interrupt is initiated when the E-bit error counter changes form FFH to 0H. 1 - unmasked, 0 - masked. Interrupt vector = 00010000.
6	CRCO (0)	CRC-4 Error Counter Overflow Interrupt. When unmasked an interrupt is initiated when the CRC-4 error counter changes form FFH to 0H. 1 - unmasked, 0 - masked. Interrupt vector = 00010000.
5	CALNI (0)	CRC-4 Alignment Interrupt. When unmasked an interrupt is initiated when the CALN status bit of page 3, address 12H changes state. 1 - unmasked, 0 - masked. Interrupt vector = 00001000.
4	FERO (0)	Frame Alignment Signal Error Counter Overflow Interrupt. When unmasked an interrupt is initiated when the frame alignment signal error counter changes form FFH to 0H. 1 - unmasked, 0 - masked. Interrupt vector = 00010000.
3	RCRO (0)	RAI and Continuous CRC-4 Error Counter Overflow Interrupt. When unmasked an interrupt is initiated when the RAI and Continuous error counter changes form FFH to 0H. 1 - unmasked, 0 - masked. Interrupt vector = 00010000.
2	BERO (0)	Bit Error Counter Overflow Interrupt. When unmasked an interrupt is initiated when the bit error counter changes form FFH to 0H. 1 - unmasked, 0 - masked. Interrupt vector = 00010000.
1	AUXPI (0)	Auxiliary Pattern Interrupt. When unmasked an interrupt is initiated when the AUXP status bit of page 3, address 15H goes high. 1 - unmasked, 0 - masked. Interrupt vector = 01000000.
0	---	Unused.

**Table 38 - Interrupt Mask Word Two  
(Page 1, Address 1DH)**

Bit	Name	Functional Description
7	MFSYI (0)	Multiframe Synchronization Interrupt. When unmasked an interrupt is initiated when multiframe synchronization is lost. 1 - unmasked, 0 - masked. Interrupt vector = 10000000.
6	CSYNI (0)	CRC-4 Multiframe Alignment. When unmasked an interrupt is initiated when CRC-4 multiframe synchronization is lost. 1 - unmasked, 0 - masked. Interrupt vector = 10000000.
5	RFALI (0)	Remote Failure Interrupt. When unmasked an interrupt is initiated when the near end detects a failure of the remote end CRC-4 process based on the receive E-bit error count. See the RFAIL status bit description of page 3, address 19H. 1 - unmasked, 0 - masked. Interrupt vector = 10000000.
4	YI (0)	Remote Multiframe Loss Interrupt. When unmasked an interrupt is initiated when a remote multiframe alarm signal is received. 1 - unmasked, 0 - masked. Interrupt vector = 10000000.
3	1SECI (0)	One Second Status. When unmasked an interrupt is initiated when the 1SEC status bit changes state. 1 - unmasked, 0 - masked. Interrupt vector = 00001000.
2	STOP (0)	Stop Interrupt. When unmasked an interrupt is initiated when either STOP0, STOP1, $\overline{\text{STOP0}}$ or $\overline{\text{STOP1}}$ is high and a match or a mismatch between the received data, and the data in the code detect word (CDW) and detect word mask (DWM). 1 - unmasked, 0 - masked. Interrupt vector = 00000010.
1	STRT (0)	Start Interrupt. When unmasked an interrupt is initiated when either START0, START1, $\overline{\text{START0}}$ or $\overline{\text{START1}}$ is high and a match or a mismatch is made between the received data, and the data in the code detect word (CDW) and detect word mask (DWM). 1 - unmasked, 0 - masked. Interrupt vector = 00000010.
0	DATA (0)	Data Interrupt. When unmasked an interrupt is initiated when the data received in selected time slots (per time slot control words) matches the data in the code detect word (CDW). 1 - unmasked, 0 - masked. Interrupt vector = 00000010.

Table 39 - Interrupt Mask Word Three  
(Page 1, Address 1EH)

Control Page 2

Tables 40 to 50 describe the bit functions of the page 2 control registers. ( ) in the "Name" column of these tables indicates the state of the control bit after a RESET or RST function.

Bit	Name	Functional Description
7	BPVE (0)	Bipolar Violation Error Insertion. A zero-to-one transition of this inserts a single bipolar violation error into the transmit PCM 30 data. A one, zero or one-to-zero transition has no function.
6	CRCE (0)	CRC-4 Error Insertion. A zero-to-one transition of this bit inserts a single CRC-4 error into the transmit PCM 30 data. A one, zero or one-to-zero transition has no function.
5	FASE (0)	Frame Alignment Signal Error Insertion. A zero-to-one transition of this bit inserts a single error into the time slot zero frame alignment signal of the transmit PCM 30 data. A one, zero or one-to-zero transition has no function.
4	NFSE (0)	Non-frame Alignment Signal Error Insertion. A zero-to-one transition of this bit inserts a single error into bit two of the time slot zero non-frame alignment signal of the transmit PCM 30 data. A one, zero or one-to-zero transition has no function.
3	LOSE (0)	Loss of Signal Error Insertion. If one, the MT9079 transmits an all zeros signal (no pulses) in every PCM 30 time slot. When HDB3 encoding is activated no violations are transmitted. If zero, data is transmitted normally.
2	---	Unused.
1	RxG704 (0)	Receive G.704 Framing Enable. If high, the receive G.704 framing functions are disabled. The device will pass unframed G.703 data received on RxA and RxB through the device unaltered to DSTo. Once unframed data has been received the synchronization status bits will indicate an out-of-synchronization state. When low, this bit enables the receive G.704 framing functions of the device and the synchronization status bits will function normally.
0	DBNCE (0)	Debounce Select. This bit selects the debounce period (1 for 14 msec.; 0 for no debounce). Note: there may be as much as 2 msec. added to this duration because the state change of the signalling equipment is not synchronous with the PCM 30 signalling multiframe.

Table 40 - Error and Debounce Selection Word  
(Page 2, Address 10H)

Bit	Name	Functional Description
7 - 0	CMP7 - CMP0 (00H)	Bit Error Rate Compare Word 7 to 0. CMP7 is the most significant bit and CMP0 is the least significant bit of a bit pattern that is compared with the data of the selected receive circular buffer one. When individual bit mismatches are detected the Bit Error Rate Counter (BERC) is incremented.

**Table 41 - Bit Error Rate Compare Word (Page 2, Address 11H)**

Bit	Name	Functional Description
7	$\overline{\text{START0}}$ (0)	Start Receive Circular Buffer Zero. If one, circular buffer zero will start to accumulate data when a mismatch is made between the selected received data and the data of the code detect word. If zero, this feature is disabled.
6	START0 (0)	Start Receive Circular Buffer Zero. If one, circular buffer zero will start to accumulate data when a positive match is made between the selected received data and the data of the code detect word. If zero, this feature is disabled.
5	$\overline{\text{START1}}$ (0)	Start Receive Circular Buffer One. If one, circular buffer one will start to accumulate data when a mismatch is made between the selected received data and the data of the code detect word. If zero, this feature is disabled.
4	START1 (0)	Start Receive Circular Buffer One. If one, circular buffer one will start to accumulate data when a positive match is made between the selected received data and the data of the code detect word. If zero, this feature is disabled.
3	$\overline{\text{STOP0}}$ (0)	Stop Receive Circular Buffer Zero. If one, circular buffer zero will stop accumulating data when a mismatch is made between the selected received data and the data of the code detect word. If zero, this feature is disabled.
2	STOP0 (0)	Stop Receive Circular Buffer Zero. If one, circular buffer zero will stop accumulating data when a positive match is made between the selected received data and the data of the code detect word. If zero, this feature is disabled.

**Table 42 - Circular Buffer Accumulate Control Word (Page 2, Address 12H)**

Bit	Name	Functional Description
1	$\overline{\text{STOP1}}$ (0)	Stop Receive Circular Buffer One. If one, circular buffer one will stop accumulating data when a mismatch is made between the selected received data and the data of the code detect word. If zero, this feature is disabled.
0	STOP1 (0)	Stop Receive Circular Buffer One. If one, circular buffer one will stop accumulating data when a positive match is made between the selected received data and the data of the code detect word. If zero, this feature is disabled.

**Table 42 - Circular Buffer Accumulate Control Word (Page 2, Address 12H)**

Bit	Name	Functional Description
7 - 6	---	Unused.
5	LDCRC (0)	CRC-4 Error Load Word. Data is loaded into the CRC-4 Error counter when this bit is changed from low to high.
4	LDEC (0)	E-bit Error Load Word. Data is loaded into the E-bit Error counter when this bit is changed from low to high.
3	LDBPV (0)	Bipolar Violation Load Word. Data is loaded into the Bipolar Violation counter when this bit is changed from low to high.
2	LDEF (0)	Errored Frame Alignment Load Word. Data is loaded into the Errored Frame Alignment counter when this bit is changed from low to high.
1	LDRC (0)	RAI and Continuous CRC Error Load Word. Data is loaded into the RAI and Continuous CRC Error counter when this bit is changed from low to high.
0	LDBER (0)	Bit Error Rate Load Word. Data is loaded into the eight bit BER counter when this bit is changed from low to high.

**Table 43 - Counter Load Control Word (Page 2, Address 15H) (Valid in ST-BUS mode only)**



Bit	Name	Functional Description
7 - 0	BRLD7 - BRLD0	Bit Error Rate Load Word. This bit pattern is loaded into the bit error rate counter when LDBER is toggled (valid in ST-BUS mode only).

**Table 44 - Bit Error Rate Load Word (Page 2, Address 18H)**

Bit	Name	Functional Description
7 - 0	ECLD7 - ECLD0	E-bit Error Counter Load Word. This bit pattern is loaded into the E-bit error counter when LDEC is toggled (valid in ST-BUS mode only).

**Table 49 - E-bit Error Counter Load Word (Page 2, Address 1EH)**

Bit	Name	Functional Description
7 - 0	RCLD7 - RCLD0	RAI and Continuous CRC Error Load Word. This bit pattern is loaded into the RAI and continuous CRC error counter when LDRC is toggled (valid in ST-BUS mode only).

**Table 45 - RAI and Continuous CRC Error Counter Load Word (Page 2, Address 19H)**

Bit	Name	Functional Description
7 - 0	CCLD7 - CCLD0	CRC-4 Error Counter Load Word. This bit pattern is loaded into the CRC-4 Error Counter when LDCRC is toggled (valid in ST-BUS mode only).

**Table 50 - CRC-4 Error Counter Load Word (Page 2, Address 1FH)**

Bit	Name	Functional Description
7 - 0	EFLD7 - EFLD0	Errored Frame Alignment Load Word. This bit pattern is loaded into the errored frame alignment signal counter when LDEF is toggled (valid in ST-BUS mode only).

**Table 46 - Errored Frame Alignment Load Word (Page 2, Address 1AH)**

Bit	Name	Functional Description
7 - 0	BPLD15 - BPLD8	Bipolar Violation Load Word. This bit pattern is loaded into the most significant bits of the bipolar Violation counter when LDBPV is toggled (valid in ST-BUS mode only).

**Table 47 - Most Significant Bipolar Violation Load Word (Page 2, Address 1CH)**

Bit	Name	Functional Description
7 - 0	BPLD7 - BPLD0	Bipolar Violation Load Word. This bit pattern is loaded into the least significant bits of the Bipolar Violation Counter. These bits are loaded when LDBPV is toggled.

**Table 48 - Least Significant Bipolar Violation Load Word (Page 2, Address 1DH)**

## Status Page 3

Tables 51 to 58 describe the bit functions of the page 3 status registers.

Bit	Name	Functional Description
7	$\overline{\text{SYNC}}$	Receive Basic Frame Alignment. Indicates the basic frame alignment status (1 - loss; 0 - acquired).
6	$\overline{\text{MFSYNC}}$	Receive Multiframe Alignment. Indicates the multiframe alignment status (1 - loss; 0 -acquired).
5	$\overline{\text{CRCSYN}}$	Receive CRC-4 Synchronization. Indicates the CRC-4 multiframe alignment status (1 - loss; 0 - acquired).
4	REB1	Receive E-Bit One Status. This bit indicates the status of the received E1 bit of the last multiframe.
3	REB2	Receive E-Bit Two Status. This bit indicates the status of the received E2 bit of the last multiframe.
2	CRCRF	CRC-4 Reframe. A one indicates that the receive CRC-4 multiframe synchronization could not be found within the time out period of 8 msec. after detecting basic frame synchronization. This bit is cleared when CRC-4 synchronization is achieved.
1	PSYNC	Synchronization Persistence. This bit will go high when the $\overline{\text{SYNC}}$ status bit goes high (loss of basic frame alignment). It will persist high for eight msec. after $\overline{\text{SYNC}}$ has returned low, and then return low.
0	CRCIWK	CRC-4 Interworking. This bit indicates the CRC-4 interworking status (1 - CRC-to-CRC; 0 - CRC-to-non-CRC).

**Table 51 - Synchronization Status Word  
(Page 3, Address 10H)**

Bit	Name	Functional Description
7	RIU0	Receive International Use Zero. This is the bit which is received on the PCM 30 2048 kbit/sec. link in bit position one of the frame alignment signal. It is used for the CRC-4 remainder or for international use.
6 - 0	RFA2-8	Receive Frame Alignment Signal Bits 2 to 8. These bit are received on the PCM 30 2048 kbit/sec. link in bit positions two to eight of frame alignment signal. These bits form the frame alignment signal and should be 0011011.

**Table 52 - Receive Frame Alignment Signal  
(Page 3, Address 11H)**

Bit	Name	Functional Description
7	1SEC	One Second Timer Status. This bit changes state once every 0.5 seconds and is synchronous with the 2SEC timer.
6	2SEC	Two Second Timer Status. This bit changes state once every second and is synchronous with the 1SEC timer.
5	CRCT	CRC-4 Timer Status. This bit changes from one-to-zero at the start of the one second interval in which CRC errors are accumulated. This bit stays high for 8 msec.
4	EBT	E-Bit Timer Status. This bit changes from one-to-zero at the start of the one second interval in which E-bit errors are accumulated. This bit stays high for 8 msec.
3	400T	400 msec. Timer Status. This bit changes state when the 400 msec. CRC-4 multiframe alignment timer expires.
2	8T	8 msec. Timer Status. This bit changes state when the 8 msec. CRC-4 multiframe alignment timer expires.
1	CALN	CRC-4 Alignment. When CRC-4 multiframe alignment has not been achieved this bit changes state every 2 msec. When CRC-4 multiframe alignment has been achieved this bit is synchronous with the receive CRC-4 multiframe signal.
0	---	Unused.

**Table 53 - Timer Status Word  
(Page 3, Address 12H)**

Bit	Name	Functional Description
7	RIU1	Receive International Use 1. This bit is received on the PCM 30 2048 kbit/sec. link in bit position one of the non-frame alignment signal. It is used for CRC-4 multiframe alignment or international use.
6	RNFAB	Receive Non-frame Alignment Bit. This bit is received on the PCM 30 2048 kbit/sec. link in bit position two of the non-frame alignment signal. This bit should be one in order to differentiate between frame alignment frames and non-frame alignment frames.
5	RALM	Receive Alarm. This bit is received on the PCM 30 2048 kbit/sec. link in bit position three of the non-frame alignment signal. It is used to indicate an alarm from the remote end of the PCM 30 link (1 - alarm, 0 - normal).
4 - 0	RNU4-8	Receive National Use Four to Eight. These bits are received on the PCM 30 2048 kbit/sec. link in bit positions four to eight of the non-frame alignment signal.

**Table 54 - Receive Non-frame Alignment Signal (Page 3, Address 13H)**

Bit	Name	Functional Description
7 - 4	RMA1-4	Receive Multiframe Alignment Bits One to Four. These bits are received on the PCM 30 2048 kbit/sec. link in bit positions one to four of time slot 16 of frame zero of every multiframe. These bit should be 0000 for proper multiframe alignment.
3	X1	Receive Spare Bit X1. This bit is received on the PCM 30 2048 kbit/sec. link in bit position five of time slot 16 of frame zero of every multiframe.
2	Y	Receive Y-bit Alarm. This bit is received on the PCM 30 2048 kbit/sec. link in bit position six of time slot 16 of frame zero of every multiframe. It indicates loss of multiframe alignment at the remote end (1 -loss of multiframe alignment; 0 - multiframe alignment acquired).
1 - 0	X2, X3	Receive Spare Bits X2 and X3. These bits are received on the PCM 30 2048 kbit/sec. link in bit positions seven and eight respectively, of time slot 16 of frame zero of every multiframe.

**Table 55 - Receive Multiframe Alignment Signal (Page 3, Address 14H)**

Bit	Name	Functional Description
7	RSLIP	Receive Slip. A change of state (i.e., 1-to-0 or 0-to-1) indicates that a receive controlled frame slip has occurred.
6	RSLPD	Receive Slip Direction. If one, indicates that the last received frame slip resulted in a repeated frame, i.e., system clock (C4i/C2i) faster than network clock (ECLK). If zero, indicates that the last received frame slip resulted in a lost frame, i.e., system clock slower than network clock. Updated on an RSLIP occurrence basis.
5	AUXP	Auxiliary Pattern. This bit will go high when a continuous 101010... bit stream (Auxiliary Pattern) is received on the PCM 30 link for a period of at least 512 bits. If zero, auxiliary pattern is not being received. This pattern will be decoded in the presents of a bit error rate of as much as $10^{-3}$ .
4	CEFS	Consecutively Errored Frame Alignment Signal. This bit goes high when the last two frame alignment signals were received in error. This bit will be low when at least one of the last two frame alignment signals is without error.
3	RxFRM	Receive Frame. The most significant bit of the phase status word. If one, the phase status word is greater than one frame in length; if zero, the phase status word is less than one frame in length.
2 - 0	RxTS4-2	Receive Time Slot. The three most significant bits of a five bit counter that indicates the number of time slots between the ST-BUS frame pulse and E8Ko.

**Table 56 - Most Significant Phase Status Word (Page 3, Address 15H)**

Bit	Name	Functional Description
7 - 6	RxTS1-0	Receive Time Slot. The two least significant bits of a five bit counter that indicates the number of time slots between the ST-BUS frame pulse and E8Ko.
5 - 3	RxBC2 -0	Receive Bit Count. A three bit counter that indicates the number of bits between the ST-BUS frame pulse and E8Ko.
2 - 0	RxEBC2 -0	Receive Eighth Bit Count. A three bit counter that indicates the number of one eighth bit times there are between the ST-BUS frame pulse and E8Ko. These least significant bits are valid only when the device is clocked at 4.096 MHz. The accuracy of the this measurement is approximately $\pm 1/16$ (one sixteenth) of a bit.

**Table 57 - Least Significant Phase Status Word (Page 3, Address 16H)**

Bit	Name	Functional Description
7	CRCS1	Receive CRC Error Status One. If one, the evaluation of the last received submultiframe one resulted in an error. If zero, the last submultiframe one was error free. Updated on a submultiframe one basis.
6	CRCS2	Receive CRC Error Status Two. If one, the evaluation of the last received submultiframe two resulted in an error. If zero, the last submultiframe two was error free. Updated on a submultiframe two basis.
5	RFAIL	Remote CRC-4 Multiframe Generator/detector Failure. If one, each of the previous five seconds have an E-bit error count of greater than 989, and for this same period the receive RAI bit was zero (no remote alarm), and for the same period the SYNC bit was equal to zero (basic frame alignment has been maintained). If zero, indicates normal operation.

**Table 58 - Alarm Status Word One (Page 3, Address 19H) (continued)**

Bit	Name	Functional Description
4	LOSS	Loss of Signal Status Indication. If one, indicates the presence of a loss of signal condition. If zero, indicates normal operation. A loss of signal condition occurs when there is an absence of the receive PCM 30 signal for 255 contiguous pulse (bit) positions from the last received pulse. A loss of signal condition terminates when an average ones density of at least 12.5% has been received over a period of 255 contiguous pulse positions starting with a pulse.
3	AIS16S	Alarm Indication Signal 16 Status. If one, indicates an all ones alarm is being received in channel 16. If zero, normal operation. Updated on a frame basis.
2	AISS	Alarm Indication Status Signal. If one, indicates that a valid AIS or all ones signal is being received. If zero, indicates that a valid AIS signal is not being received. The criteria for AIS detection is determined by the control bit ASEL.
1	RAIS	Remote Alarm Indication Status. If one, there is currently a remote alarm condition. If zero, normal operation. Updated on a non-frame alignment frame basis.
0	RCRS	RAI and Continuous CRC Error Status. If one, there is currently an RAI and continuous CRC error condition. If zero, normal operation. Updated on a submultiframe basis.

**Table 58 - Alarm Status Word One (Page 3, Address 19H) (continued)**

Status Page 4

Tables 59 to 66 describe the bit functions of the page 4 status registers and counters. The Internal Vector Status Word is cleared automatically after it is read by the microprocessor. The RESET and RST functions do not affect the page 4 counters. Therefore, individual counters must be initialized to a starting value by a write operation or a counter load operation (Table 43) in ST-BUS control mode. When presetting or clearing the BPV counter, BPV7-BPV0 should be written to first, and BPV15-BPV8 should be written to last.

Bit	Name	Functional Description
7 - 0	IV7 - IV0	Interrupt Vector Bits 7 to 0. The interrupt vector status word contains an interrupt vector that indicates the category of the last interrupt. See the section on interrupts.

Table 59 - Interrupt Vector Status Word (Page 4, Address 12H)

Bit	Name	Functional Description
7 - 0	BR7 - BR0	Bit Error Rate Counter. An eight bit counter that contains the total number of bit errors received in a specific time slot. See the BFAS control bit function of page 1, address 1AH.

Table 60 - Bit Error Rate Counter (Page 4, Address 18H)

Bit	Name	Functional Description
7 - 0	RCRC7 - RCRC0	RAI and Continuous CRC Error Counter. An 8 bit counter that is incremented once for every concurrent occurrence of the receive RAI equal to one and either E-bit equal to zero. Updated on a multiframe basis.

Table 61 - RAI and Continuous CRC Error Counter (Page 4, Address 19H)

Bit	Name	Functional Description
7 - 0	EFAS7 - EFAS0	Errored FAS Counter. An 8 bit counter that is incremented once for every receive frame alignment signal that contains one or more errors.

Table 62 - Errored Frame Alignment Signal Counter (Page 4, Address 1AH)

Bit	Name	Functional Description
7 - 0	BPV15 - BPV8	Most Significant Bits of the BPV Counter. The most significant eight bits of a 16 bit counter that is incremented once for every bipolar violation error received.

Table 63 - Most Significant Bits of the BPV Counter (Page 4, Address 1CH)

Bit	Name	Functional Description
7 - 0	BPV7 - BPV0	Least Significant Bits of the BPV Counter. The least significant eight bits of a 16 bit counter that is incremented once for every bipolar violation error received.

Table 64 - Least Significant Bits of the BPV Counter (Page 4, Address 1DH)

Bit	Name	Functional Description
7 - 0	EC7 - EC0	E-bit Error Counter Bits Seven to Zero. These are the least significant eight bits of the E-bit error counter.

Table 65 - E-bit Error Counter EBt (Page 4, Address 1EH)

Bit	Name	Functional Description
7 - 0	CC7 - CC0	CRC-4 Error Counter Bits Seven to Zero. These are the least significant eight bits of the CRC-4 error counter.

Table 66 - CRC-4 Error Counter CET (Page 4, Address 1FH)

## Applications

### Microprocessor Interfaces

Figure 7 illustrates a circuit which connects the MT9079 to a MC68HC11 microcontroller operating at 2.1 MHz. Address lines A<sub>13</sub> - A<sub>15</sub> are decoded and latched with the AS signal to generate one of eight possible Chip Selects (CS). A<sub>8</sub> - A<sub>12</sub> are used to select the individual control and status registers of the MT9079, and AD<sub>0</sub> - AD<sub>7</sub> are used for data transfer only.

The receive and transmit data link signals can be connected directly to the MC68HC11 serial port, when it is operating in slave mode. With this circuit, it is important to make the CPHA bit high in the MC68HC11 Serial Peripheral Control Register so the SS input can be tied low.

Figure 8 shows a circuit which interfaces the MT9079 to the 80C52 microcontroller. The 80C52 RD and WR signals are used to generate a R/W signal for the MT9079. RD and WR are also re-timed using the XTAL2 output to produce a Data Strobe (DS) signal that will meet t<sub>RWS</sub>. The remainder of this interface is similar to the MC68HC11 interface.

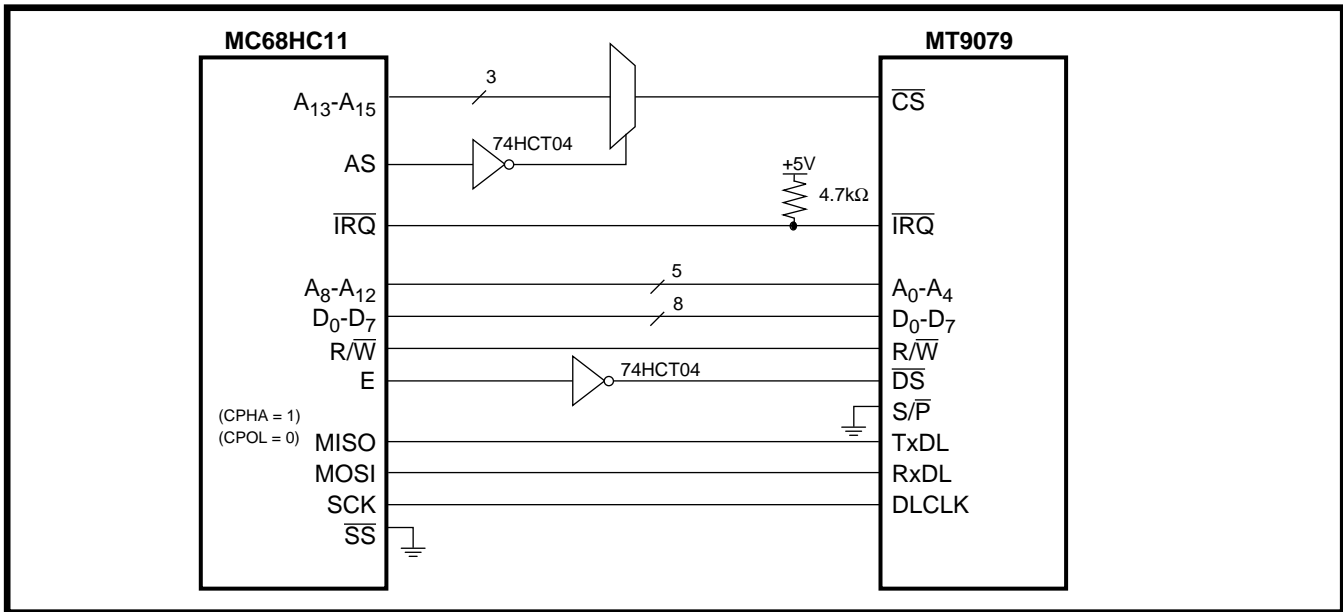

Figure 7 - MT9079 to MC68HC11 (2.1 MHz) Microcontroller Interface Circuit

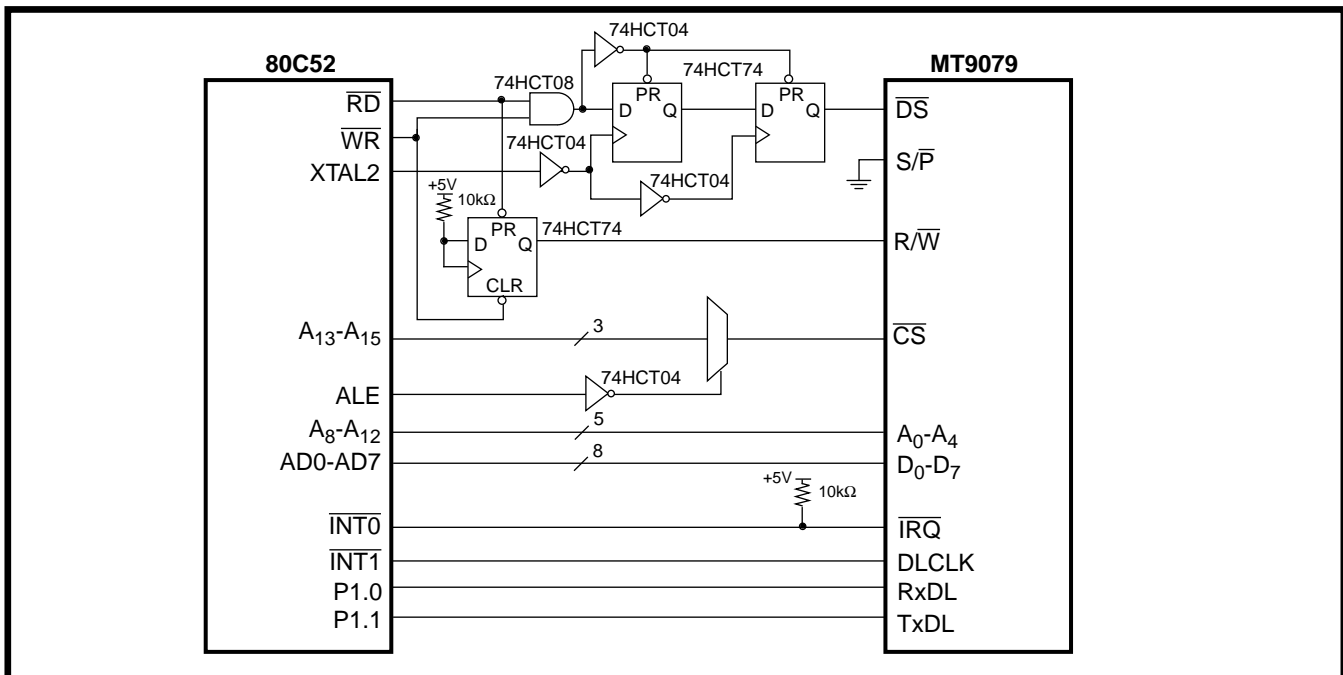

Figure 8 - MT9079 to 80C52 Microcontroller Interface Circuit

The data link transmit and receive signals are connected directly to port one. The DCLK signal is connected to INT1 so the 80C52 will be interrupted when new data link data needs to be transported.

Figure 9 illustrates a circuit that will interface the MT9079 to the MC68302 microprocessor operating at 20 MHz.  $\overline{CS0}$  was chosen so that no external address decoding would be required. The MT9079 does not have a  $\overline{DTACK}$  output therefore, the MC68302  $\overline{DTACK}$  should be tied high. The data link interface is handled by Non-multiplexed Serial Interface port Two (NMSI2).

Figure 10 shows how to connect a 16 MHz 80C188 microprocessor to the MT9079. The 80C188  $\overline{WR}$  and

$\overline{RD}$  signals are re-timed using the CLKOUT signal to generate a  $\overline{DS}$  signal for the MT9079. The inverted form of  $\overline{DT/\overline{R}}$  is used to make a  $R/\overline{W}$  signal, and the ALE is used to latch the lower order address lines for the duration of the access cycle.

### MT9079 TAIS and Reset Circuit

Figure 11 illustrates a reset and transmit AIS circuit that can be implemented with the MC68302 microprocessor. This circuit has three purposes: 1) to provide a power-on reset for the all the MT9079 devices; 2) to have all the MT9079 devices transmit AIS during system initialization; and 3) to have all the MT9079 devices transmit AIS when the MC68302 watch-dog time expires.

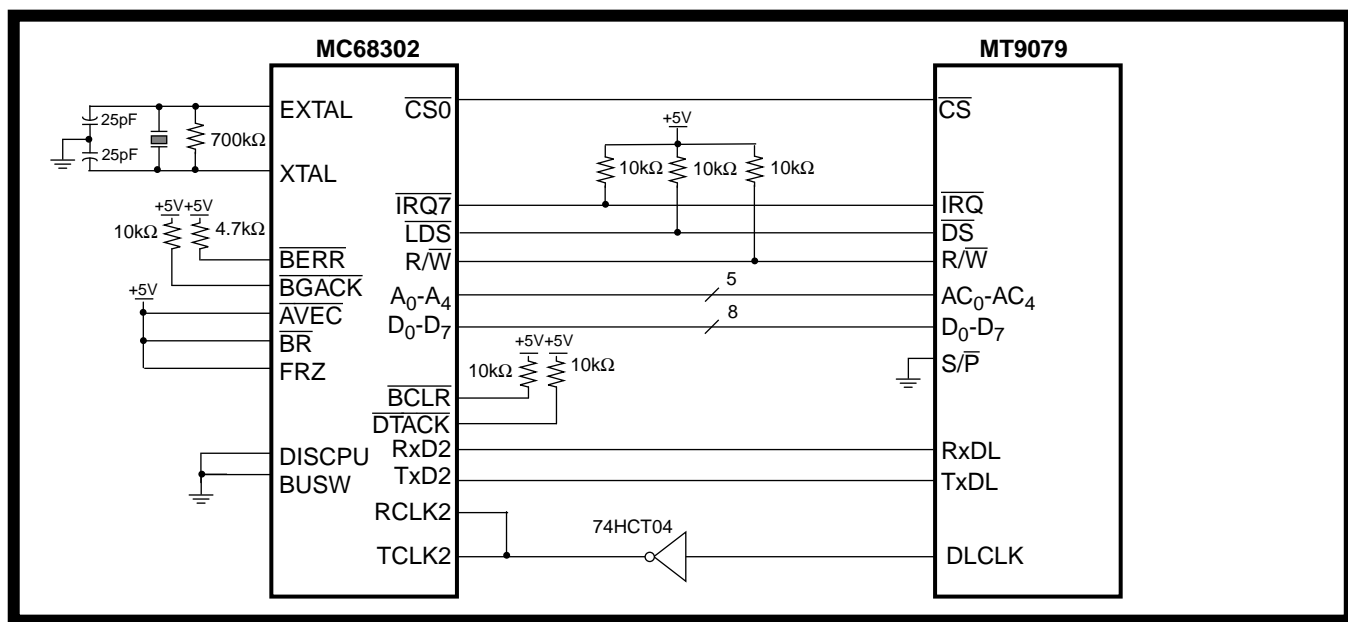

Figure 9 - MT9079 to MC68302 (20 MHz) Microprocessor Interface Circuit

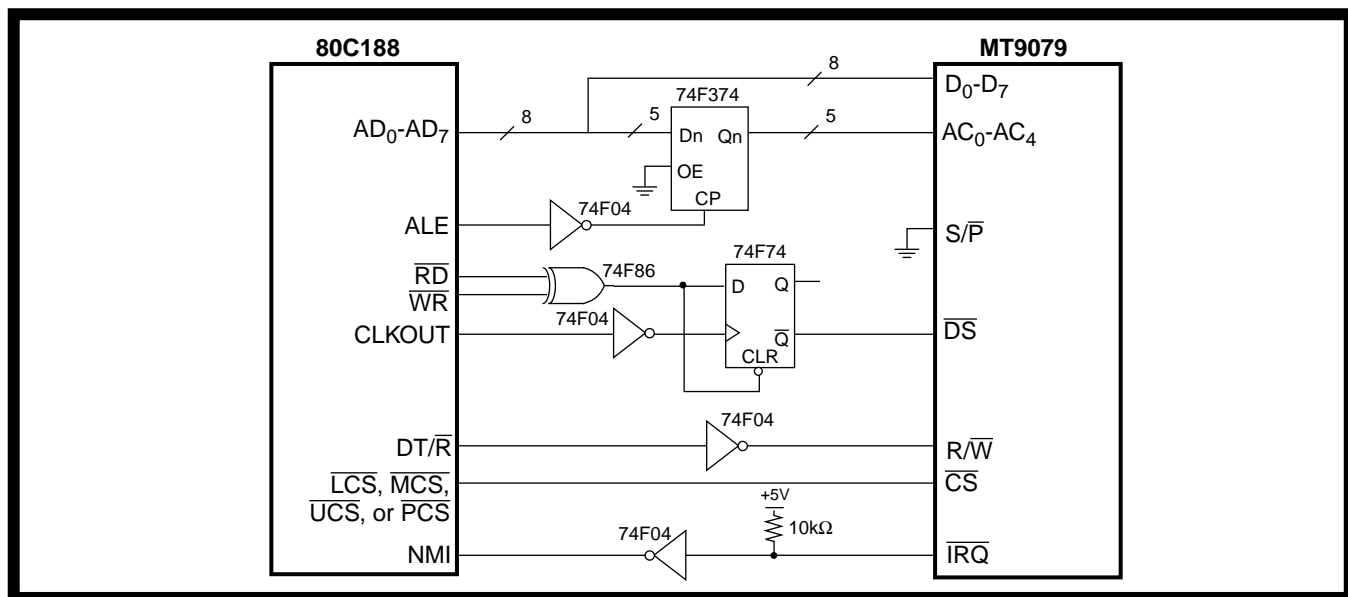

Figure 10 - MT9079 to 80C188 (16 MHz) Microprocessor Interface Circuit

# MT9079

The MC1455  $\overline{\text{RESET}}$  and  $\overline{\text{HALT}}$  circuit has been taken from the MC68302 User's Manual. The reset circuit for the MT9079 (RC) must have a time constant that is at least five times the rise time of the power supply. It should also be noted that in this application the power-on reset (POR) duration for the MT9079 devices must be greater than the duration of the power-on reset pulse for the MC68302. This will allow AIS to be transmitted without interruption during the system initialization.

During the power-on sequence the MT9079 POR circuit will ensure that AIS is transmitted on the PCM 30 trunks by putting the 74HCT74 flip-flops in the preset state. When the MT9079 POR signal goes from low to high, the 74HCT74 flip-flops will remain in the preset state and AIS will continue. After the system initialization program has been completed the AIS signal can be terminated by executing a MC68302 reset command, which makes the MC68302  $\overline{\text{RESET}}$  pin low for 24 CLKO cycles. When  $\overline{\text{RESET}}$  goes low the 74HCT74 flip-flops will be cleared and the  $\overline{\text{TAIS}}$  inputs can go high.

The MC68302 watch-dog timer must be reset periodically or the  $\overline{\text{WDOG}}$  output will go low for 16 microprocessor clock cycles (CLKO) and return high. In the circuit of Figure 11 this will reset the MC68302 and turn on the transmit AIS of all the MT9079 devices through the 74HCT74 flip-flops. The transmit

AIS will not terminate until the MC68302 reset command has been executed to clear the 74HCT74 flip-flops.

Provision has been provided to initiate the transmission of AIS on individual MT9079 devices from a control port. This function can also be accomplished by writing to the Transmit Alarm Control Word of the MT9079.

## Interface Initialization

Figure 12 is a flow chart that illustrates the basic steps involved in initializing the MT9079 from a power-on state. The post reset state of each control bit will determine which flow chart steps may be left out in specific applications.

The first step is to make  $\overline{\text{TAIS}}$  low so the MT9079 will transmit an all 1's signal during the initialization procedure. This informs the remote end of the E1 link that this end is not functioning normally. After the  $\overline{\text{RESET}}$  cycle is complete all interrupts are suspended so the microprocessor will not jump to any interrupt service routines until the interface is configured. It is important to write 00H to all the per-timeslot control words (pages 7 and 8) so that transmit timeslots are not substituted with unknown data. Next the mode of operation and timing can be selected.

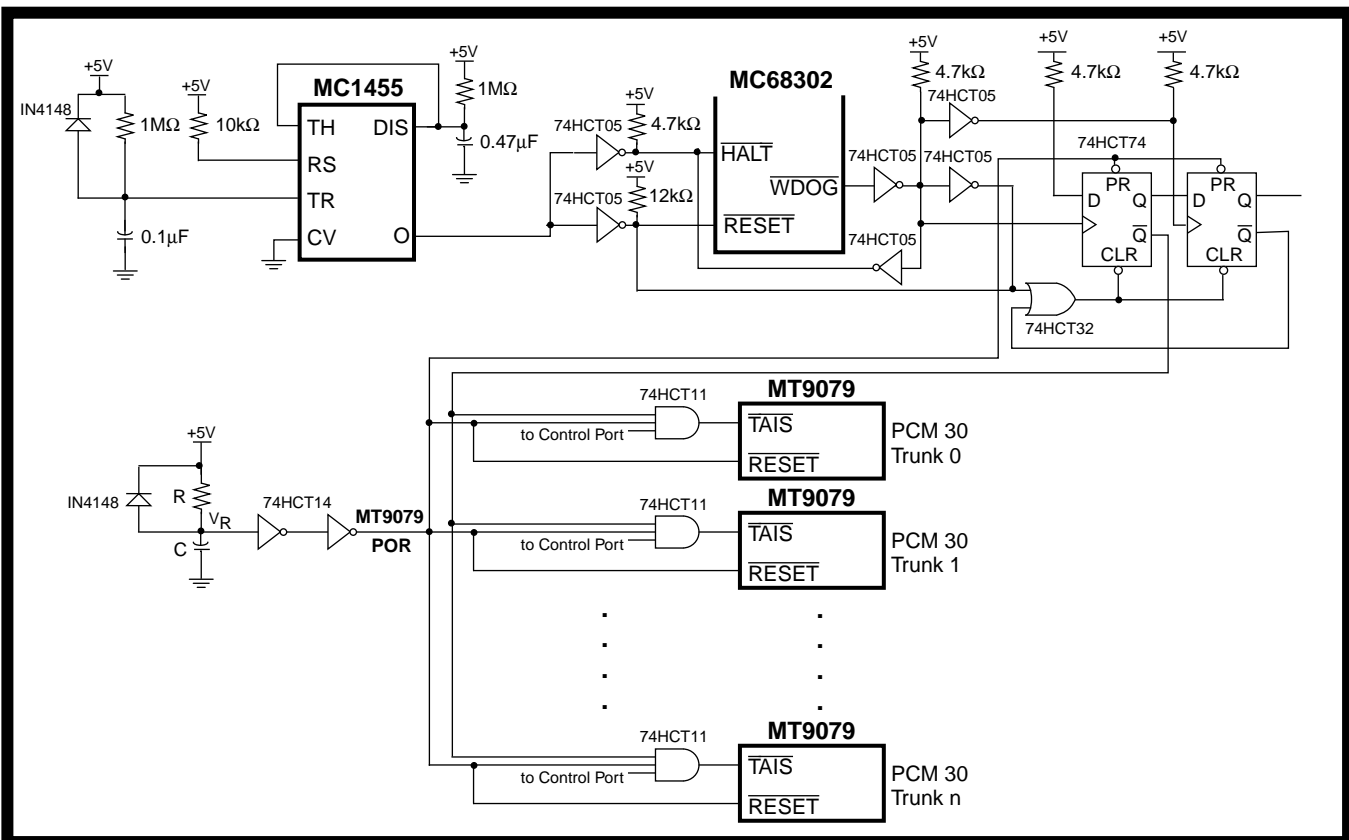
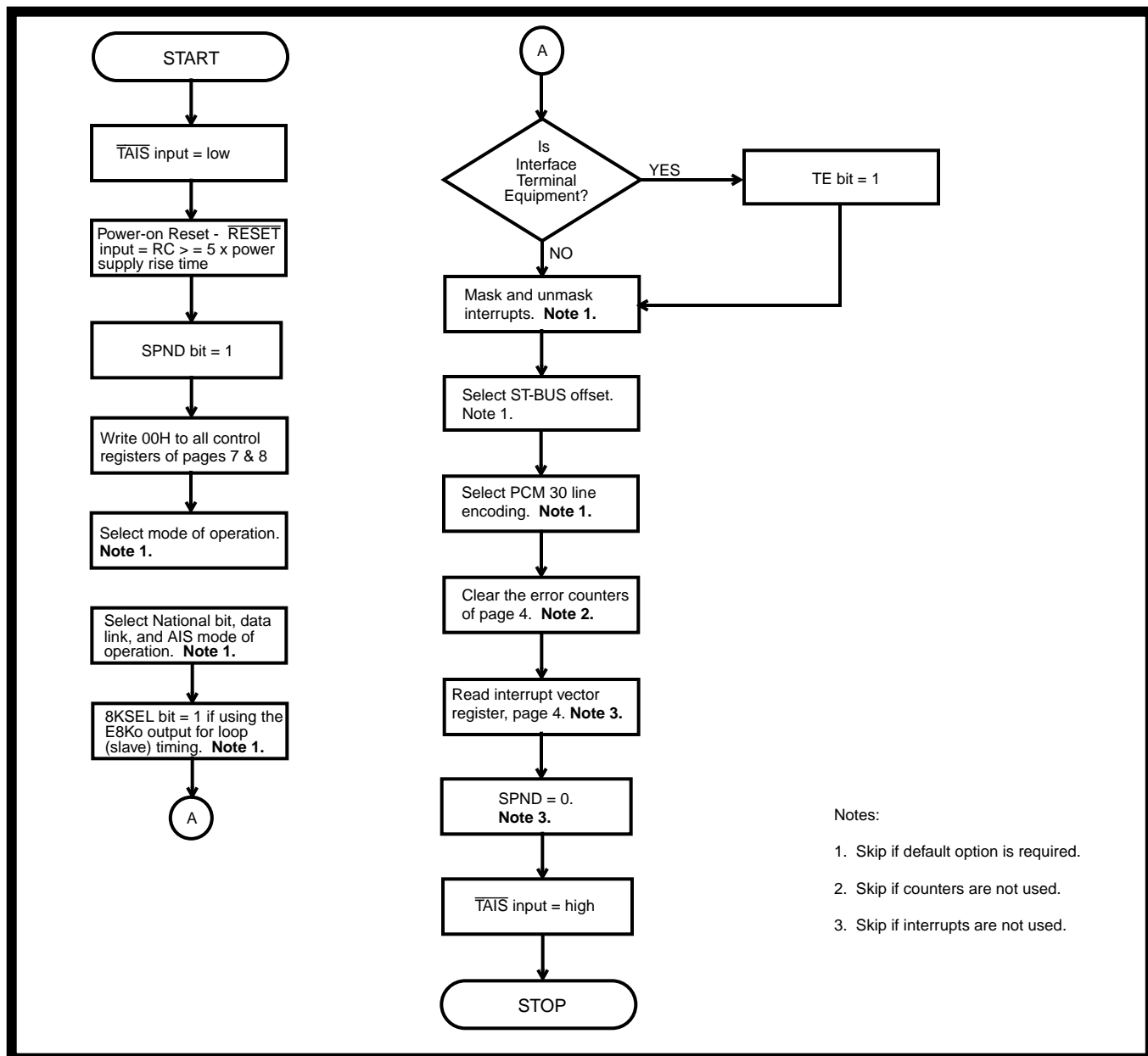

Figure 11 - MT9079 Reset and Transmit AIS Circuit





- Notes:
1. Skip if default option is required.
  2. Skip if counters are not used.
  3. Skip if interrupts are not used.

Figure 12 - MT9079 Initialization Procedure

The TE control bit sets the state of the transmit E-bits when the receive side has lost CRC-4 synchronization. In this case if the interface is the Terminal Equipment (TE) side, then the E-bits must be zero. If the interface is the Network Termination (NT) side, the transmit E-bits must be one when CRC-4 synchronization is lost. When CRC-4 synchronization is achieved the transmit E-bits will function according to ITU-T G.704.

The MT9079 has a suite of 30 maskable interrupts. At this point in the initialization procedure the  $\overline{\text{SYNI}}$ ,  $\overline{\text{RAII}}$ ,  $\overline{\text{AISI}}$ ,  $\overline{\text{AIS16I}}$ ,  $\overline{\text{LOSI}}$ ,  $\overline{\text{FERI}}$ ,  $\overline{\text{BPVO}}$  and  $\overline{\text{SLPI}}$  interrupts will be unmasked and all others will be masked. If the application does not require interrupts, the SPND control bit should be kept at one.

Adjusting the ST-BUS offset will move the bit positions of the ST-BUS output streams with respect to the input frame pulse  $\overline{\text{FOi}}$ . This can be used to compensate for large delays in very long backplane applications. It can also be used to minimize the delay through the receive elastic buffer.

Selection of the PCM 30 encoding will be determined by the line interface arrangement used. The default is HDB3 encoding on bipolar non-return to zero signals, which will interface directly to most Line Interface Units (LIU).

After a power-on reset the state of the error counters of page 4 will be undetermined. Therefore, each of the counters appropriate to the application should be cleared by writing a zero value to the counter

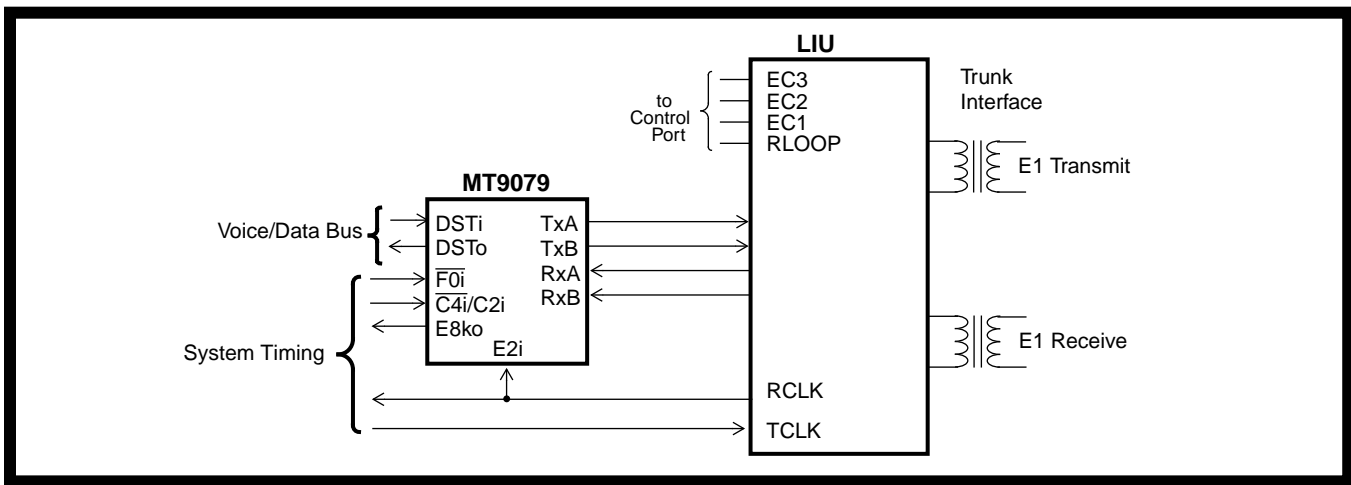

Figure 13 - PCM 30 Line Interface Unit (LIU)

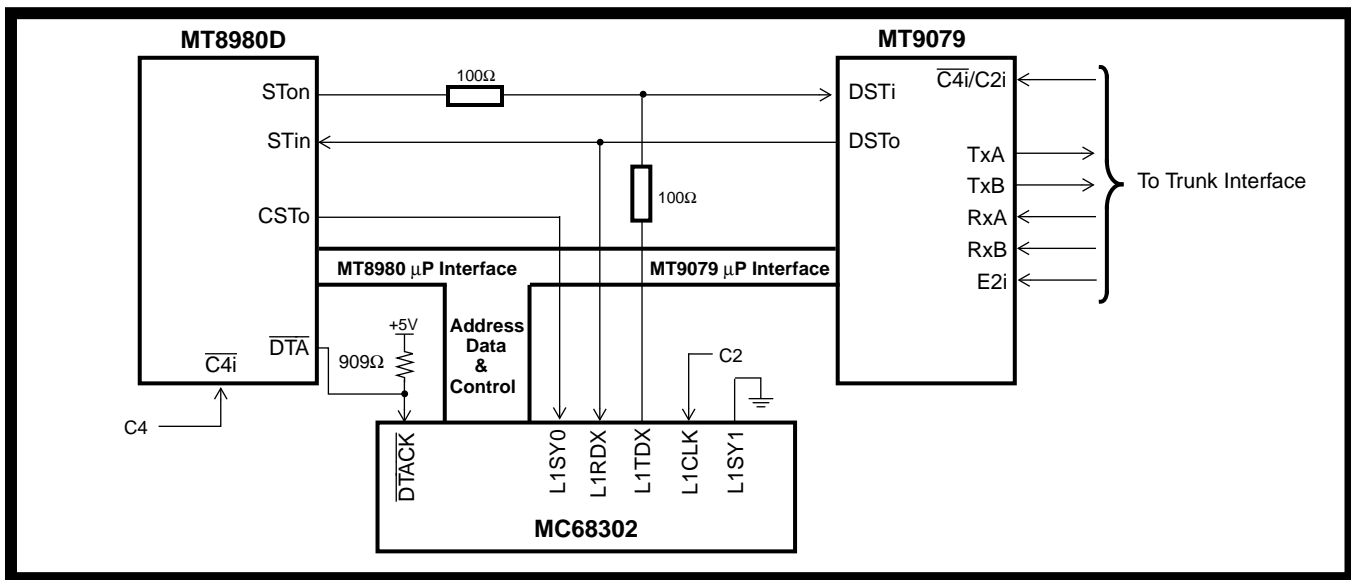

Figure 14 - Common Channel Signalling Control (Time Slot 16) through the MC68302

location. The BPV counter is cleared by writing zero to location 1DH first and then writing zero to location 1CH of page 4.

The interrupt vector byte is then cleared by reading it. This step ensures that interrupts that occurred when the interface was not initialized will be cleared before the MT9079  $\overline{IRQ}$  output is activated. The  $\overline{IRQ}$  output function is activated by making SPND low.  $\overline{TAIS}$  is now made high, which indicates to the far end of the link that this end is functional.

It should be noted that Figure 12 is an initialization example and does not imply that there is a rigid sequence that must be followed.

### PCM 30 Trunk and Timing Interface

Figure 13 shows the MT9079 connection to a generic Line Interface Unit (LIU). The LIU has three functions: 1) it converts the framed transmit signal to

the required PCM 30 pseudo-ternary signal; 2) it converts the received PCM 30 pseudo-ternary signal to a binary signal; and c) it extracts a data clock from the receive PCM 30 signal.

In order to meet network requirements, it is necessary to control the transmit equalization of the LIU (EC1 - EC3). This pre-emphasizes the transmit pulse shape so it can fit within a standard pulse template at a specific point on the transmit link.

When using a LIU that clocks data in and out with separate signals, the MT9079 remote loopback can allow bit errors to occur. This is because the MT9079 does not re-time the looped signal, so phase differences in the C2 and RCLK clock signals will impact the transmit data. This problem can be prevented by implementing the remote loopback in the LIU and controlling it from a port. Performing the remote loopback in the LIU also more closely adheres to network requirements, which state that a remote loopback should be implemented as close to the PCM 30 side of the trunk as possible.

**Common Channel Signalling Interface**

Figure 14 shows how to interface DSTi and DSTo time slot 16 to the MC68302 for the control of Common Channel Signalling (CCS) data. As can be seen in the timing diagram, the MT8980D CSto signal must be programmed to go high during the bit position just before time slot 16 (i.e., time slot 15, bit 0). This will enable the NMSI1 pins for one time slot (eight C2 cycles) when the NMSI1 port is operated in PCM mode. The STo stream of the MT8980D must also be programmed to be high impedance during time slot 16. C2 is used to clock data into and out of the NMSI1 port.

It should be noted that the  $\overline{DS}$  signal of the MC68302 must be inverted to interface to the MT8980D. Also,  $\overline{DTACK}$  must be connected to the MT8980D  $\overline{DTA}$  and pulled-up with a 909 ohms resistor.

**G.703 and G.704 Operation**

The MT9079 supports three basic G.703 2.048 Mbit/sec. configurations. The first is normal framing where receive G.703 data is clocked onto the ST-BUS based on addresses which are referenced to the receive G.704 Frame Alignment Signal (FAS). On the transmit side the ST-BUS channel zero (and optionally channel 16) are replaced by G.704 framer generated signals. The second is transparent mode, which is described in the next application section.

The third configuration is where the MT9079 passes G.703 data on to another framing device such as an HDLC controller. That is, the receive data is clocked onto the ST-BUS without any reference to a G.704 FAS and transmit data is not altered by the framer. This is described in Table 67. In this configuration the control and status functions that are associated with individual channels will not work predictably. Other functions such as HDB3 encoding, interrupts,

loopbacks, RSLIP, LOSS, AISS, AUXP and the BPV error counter work normally. The control bits CRCM, MODE and  $\overline{RxG704}$  are cleared by either a software or hardware reset.

**The MT9079 Transparent Mode**

Figure 15 illustrates an application in which the MT9079 transparent mode can be used. That is, a digital cross-connect multiplexer that switches complete PCM 30 trunks and does not require time slot switching. It should be noted that any MT9079 devices that transport time slot switched data must operate in termination mode otherwise, the CRC-4 remainder will be in error.

In transparent mode the complete PCM 30 data stream will pass through the MT9079 except for the data link ( $S_{a4}$  of the NFAS - 4kbit/sec. maintenance channel). The CRC-4 remainder will not be generated by the transmit section of the MT9079, but the CRC-4 remainder bits received on DSTi will be modified to reflect the new data link bits. This has the advantage that any CRC-4 errors that occur on the receive span will not be masked on the transmit span even though the maintenance channel has been modified. See Table 67.

The  $\overline{RxMF}$  signal must be associated with the CRC-4 multiframe (control bit MFSEL = 1), and  $\overline{RxMF}$  of the receive trunk must be connected to  $\overline{TxFMF}$  of the transmit trunk. The data delay time (DSTo to DSTi) and the  $\overline{TxFMF}$  to  $\overline{RxMF}$  delay must be equal. Therefore, a  $m + 1$  frame delay circuit is added to the  $\overline{TxFMF}$  to  $\overline{RxMF}$  connection (where: m is the delay in basic frames through the Digital Cross-Connect Matrix).

It should be noted that in the  $\overline{TxFMF}$  to  $\overline{RxMF}$  operation is only valid when the  $\overline{C4i/C2i}$  input of MT9079 devices is driven by a C4 clock signal.

Function	CRCM	MODE	$\overline{G.704}$
<b>Normal Framing Mode.</b> Both the transmit and receive sides of the MT9079 perform normal E1 G.704 framing functions. One of the Sa4 - Sa8 control bits must be selected for the DL pin interface to function.	0	0	0
<b>Transparent Mode.</b> DSTo data is aligned with the receive FAS. DSTi data passes through the transmit side of the MT9079 with only the Sa4 data altered by the DL pin interface. The CRC-4 remainder is modified (not recalculated) to reflect the altered Sa4 bit. If CRCM is low, Sa4 data is not altered by the DL pin interface.	1	1	0
<b>G.703 Framing Mode.</b> Receive G.703 data passes through the MT9079 onto DSTo without any G.704 frame alignment. Transmit data passes through the MT9079 without being altered. CRCM must be low or the transmit DL interface bits will be unpredictably inserted into the G.703 transmit data.	0	1	1

**Table 67 - 2.048 Mbit/sec. Interface Configurations**

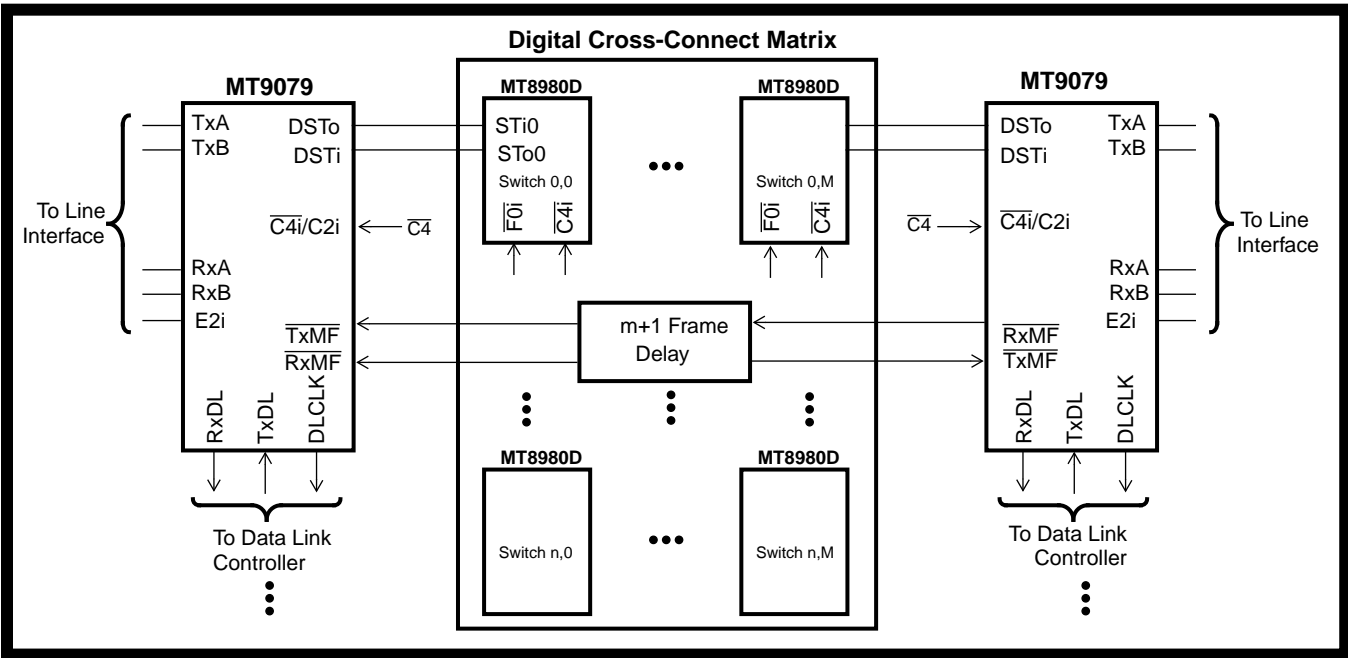

Figure 15 - PCM-30 (E1) Trunk Cross-Connect using the MT9079 Transparent Mode

## Fibre Interface

Figure 16 shows how the MT9079 can be employed to a fibre optic transmission system. The MT9079 control bits COD1-0 must be set to 01 to select Non-Return to Zero (NRZ) operation. NRZ data is manchester encoded and converted to a light signal, which is transmitted down the fibre optic cable. On

the receive side the light signal is detected and converted to an electrical signal, which is passed to a manchester decoder. The manchester decoder generates the receive NRZ signal and a receive clock.

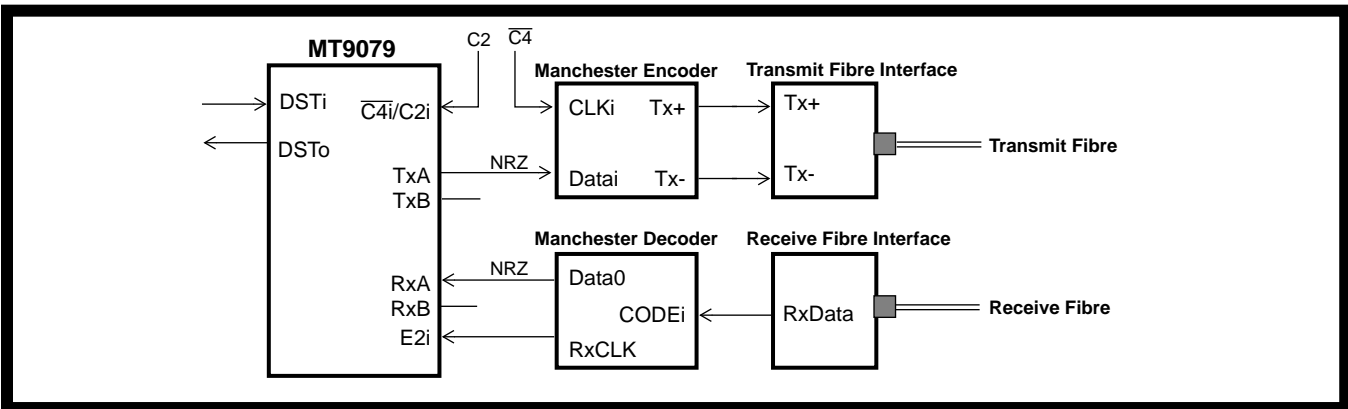

Figure 16 - MT9079 Fibre Interface Circuit

**Absolute Maximum Ratings\*** - Voltages are with respect to ground ( $V_{SS}$ ) unless otherwise stated.

	Parameter	Symbol	Min	Max	Units
1	Supply Voltage	$V_{DD}$	-0.3	7	V
2	Voltage at Digital Inputs	$V_I$	-0.3	$V_{DD} + 0.3$	V
3	Current at Digital Inputs	$I_I$		30	mA
4	Voltage at Digital Outputs	$V_O$	-0.3	$V_{DD} + 0.3$	V
5	Current at Digital Outputs	$I_O$		30	mA
6	Storage Temperature	$T_{ST}$	-65	150	°C
7	Package Power Dissipation	P		800	mW

\* Exceeding these values may cause permanent damage. Functional operation under these conditions is not implied.

**Recommended Operating Conditions** - Voltages are with respect to ground ( $V_{SS}$ ) unless otherwise stated.

	Characteristics	Sym	Min	Typ	Max	Units	Conditions/Notes
1	Operating Temperature	$T_{OP}$	-40		85	°C	
2	Supply Voltage	$V_{DD}$	4.5		5.5	V	

**DC Electrical Characteristics<sup>†</sup>** - Voltages are with respect to ground ( $V_{SS}$ ) unless otherwise stated.

	Characteristics	Sym	Min	Typ	Max	Units	Conditions/Notes
1	Power Dissipation	$P_D$			39	mW	Outputs unloaded
2	Supply Current	$I_{DD}$			7	mA	Outputs unloaded
3	Input High Voltage	$V_{IH}$	2.0		$V_{DD}$	V	
4	Input Low Voltage	$V_{IL}$	0		0.8	V	
5	Current Leakage	$I_{LK}$			10	μA	$0 \leq V \leq V_{DD}$ See Note 1
6	Output High Current	$I_{OH}$	12			mA	Source $V_{OH}=2.4$ V
7	Output Low Current	$I_{OL}$	15			mA	Sink $V_{OL}=0.4$ V
8	Pin Capacitance	$C_P$				pF	8pF typical

† Characteristics are over the ranges of recommended operating temperature and supply voltage.

Notes:

1. Maximum leakage on pins (output pin in high impedance state) is over an applied voltage (V).

**AC Electrical Characteristics - Timing Parameter Measurement Voltage Levels**

	Characteristics	Sym	Level	Units	Conditions/Notes
1	TTL Threshold Voltage	$V_{TT}$	1.5	V	See Note 1
2	CMOS Threshold Voltage	$V_{CT}$	$0.5V_{DD}$	V	See Note 1
3	Rise/Fall Threshold Voltage High	$V_{HM}$	2.0 $0.7V_{DD}$	V V	TTL CMOS See Note 1
4	Rise/Fall Threshold Voltage Low	$V_{LM}$	0.8 $0.3V_{DD}$	V V	TTL CMOS See Note 1

Notes:

1. Timing for output signals is based on the worst case result of the combination of TTL and CMOS thresholds.

## AC Electrical Characteristics- Microprocessor Timing

	Characteristics	Sym	Min	Typ	Max	Units	Conditions/Notes
1	$\overline{DS}$ low	$t_{DSL}$	70			ns	
2	$\overline{DS}$ High	$t_{DSH}$	50			ns	
3	$\overline{CS}$ Setup	$t_{CSS}$	0			ns	See Note 3
4	$R/\overline{W}$ Setup	$t_{RWS}$	5			ns	
5	Address Setup	$t_{ADS}$	5			ns	
6	$\overline{CS}$ Hold	$t_{CSH}$	0			ns	See Note 3
7	$R/\overline{W}$ Hold	$t_{RWH}$	0			ns	
8	Address Hold	$t_{ADH}$	0			ns	
9	Data Delay Read	$t_{DDR}$			120	ns	$C_L=150pF, R_L=1k\Omega$ See Note 2
10	Data Active to High Z Delay	$t_{DAZ}$			50	ns	$C_L=150pF, R_L=1k\Omega$ See Notes 1, 2 & 4
11	Data Setup Write	$t_{DSW}$	5			ns	
12	Data Hold Write	$t_{DHW}$	25			ns	

Notes:

1. High impedance is measured by pulling to the appropriate rail with  $R_L$ . Timing is corrected to cancel time taken to discharge  $C_L$ .
2. Outputs are compatible with both CMOS and TTL logic levels. Timing parameters are measured with respect to both CMOS ( $V_{CT}=0.5V_{DD}$ ) and TTL ( $V_{TT}=1.5V$ ) references and the worst case value is specified.
3.  $\overline{DS}$  and  $\overline{CS}$  may be connected together.
4.  $t_{DAZ}$  is measured with respect to the raising edge of  $\overline{DS}$  or  $\overline{CS}$ , whichever occurs first.

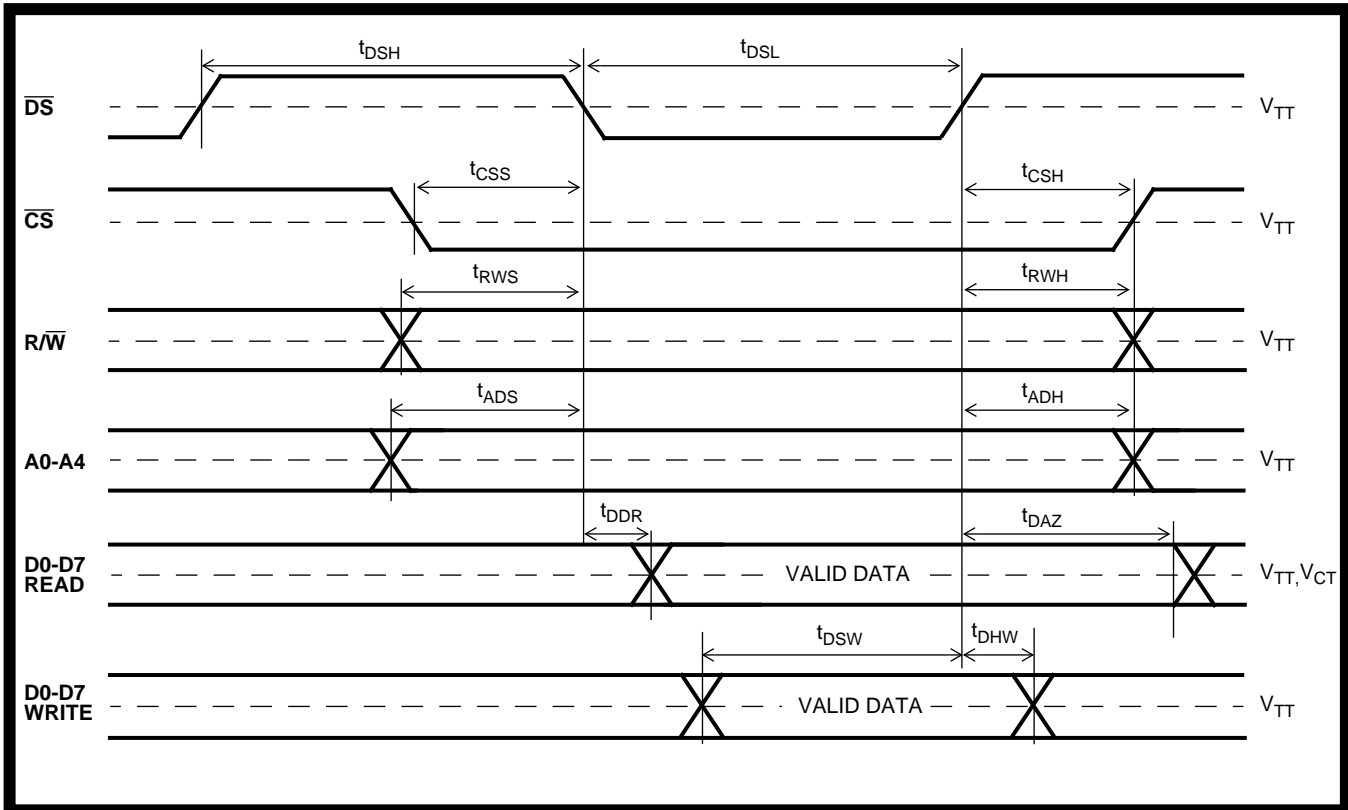

Figure 17 - Microprocessor Timing Diagram

AC Electrical Characteristics-Intel and Motorola Serial Microcontroller Timing

	Characteristics	Sym	Min	Typ	Max	Units	Conditions/Notes
1	Clock Pulse Width High	$t_{PWH}$	100		400	ns	SCLK period = 500ns
2	Clock Pulse Width Low	$t_{PWL}$	75		425	ns	SCLK period = 500ns
3	$\overline{CS}$ Setup	$t_{CSS}$	5			ns	
4	$\overline{CS}$ Hold	$t_{CSH}$	5			ns	
5	Write Setup	$t_{WS}$	35			ns	
6	Write Hold	$t_{WH}$	5			ns	
7	Output Delay	$t_{OD}$			55	ns	$C_L=150pF$
8	Active to High Z Delay	$t_{AZD}$			30	ns	$C_L=150pF, R_L=1k\Omega$

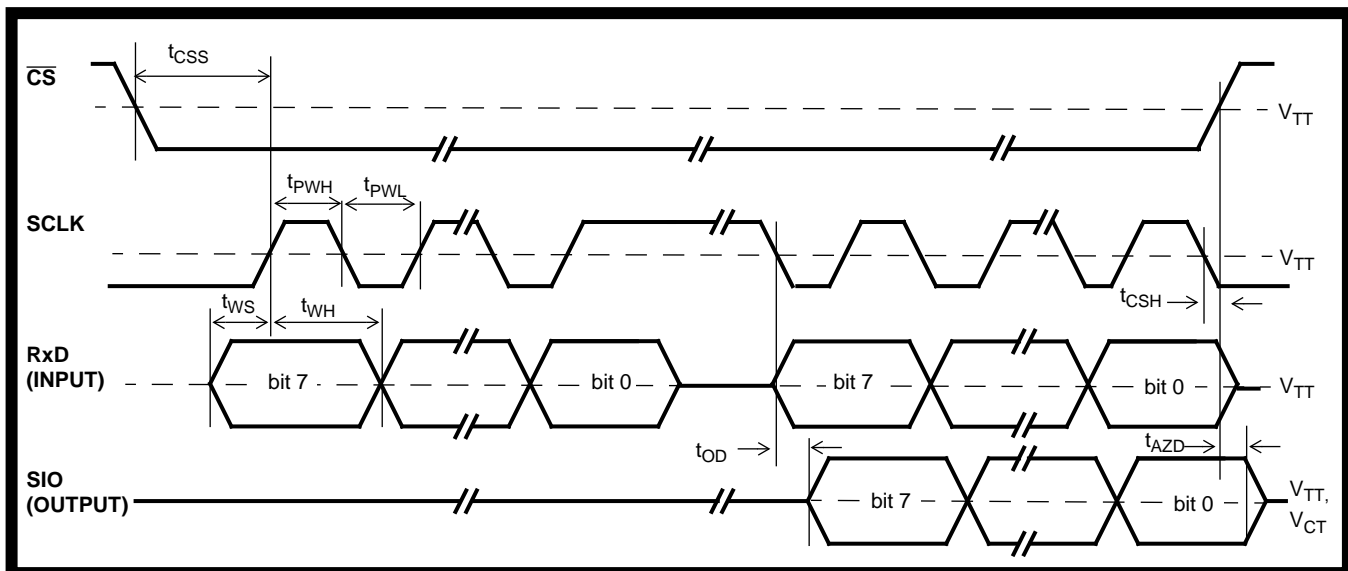

Figure 18 - Motorola Serial Microcontroller Timing

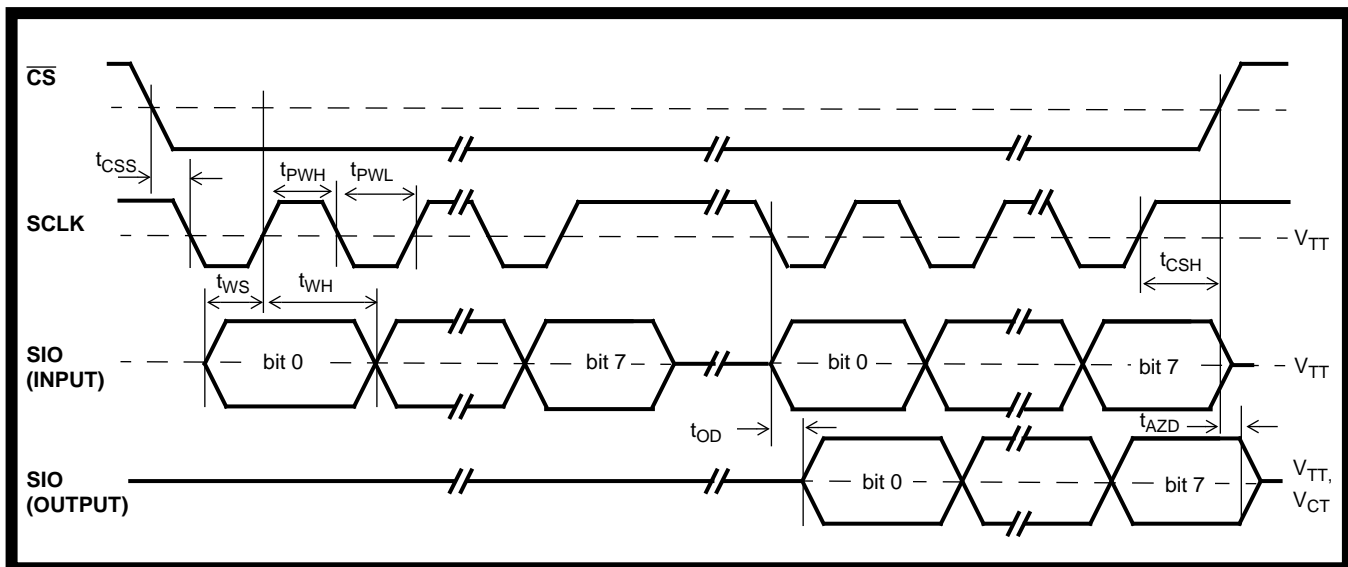

Figure 19 - Intel Serial Microcontroller Timing

## AC Electrical Characteristics - Data Link Timing

	Characteristic	Sym	Min	Typ	Max	Units	Conditions/Notes
1	Data Link Clock Output Delay	$t_{DCD}$			75	ns	150pF, See Note 1
2	Data Link Output Delay	$t_{DOD}$			75	ns	150pF
3	Data Link Setup	$t_{DLS}$	20			ns	
4	Data Link Hold	$t_{DLH}$	30			ns	

Notes:

1. The falling edge of DLCLK occurs on the channel 0, bit 4 to bit 3 boundary of every second ST-BUS frame. The falling edge of IDCLK occurs on the channel 16, bit 4 to bit 3 boundary of every second ST-BUS frame.

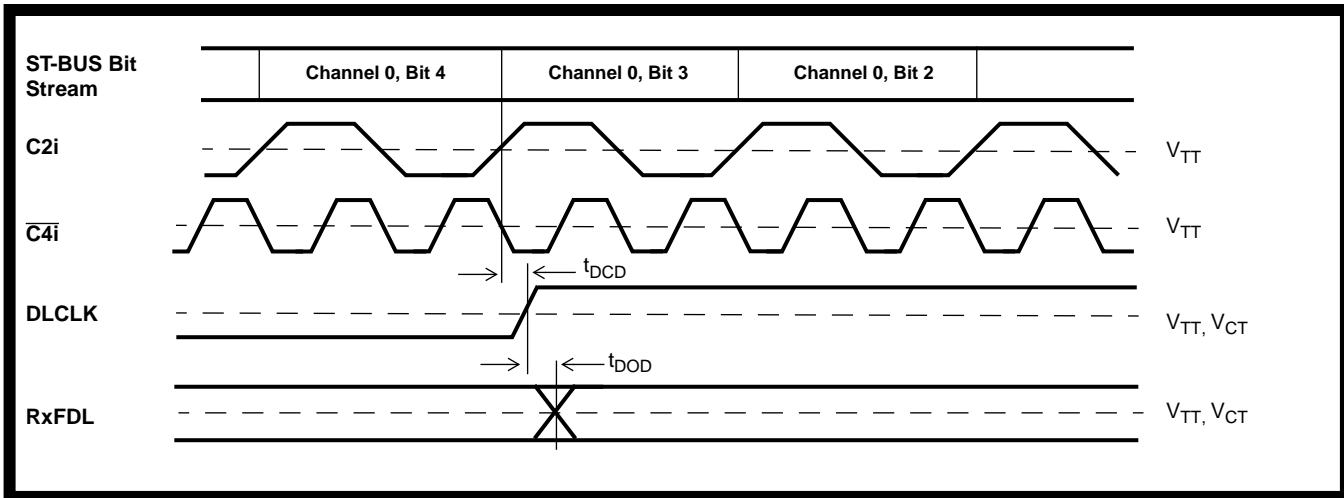
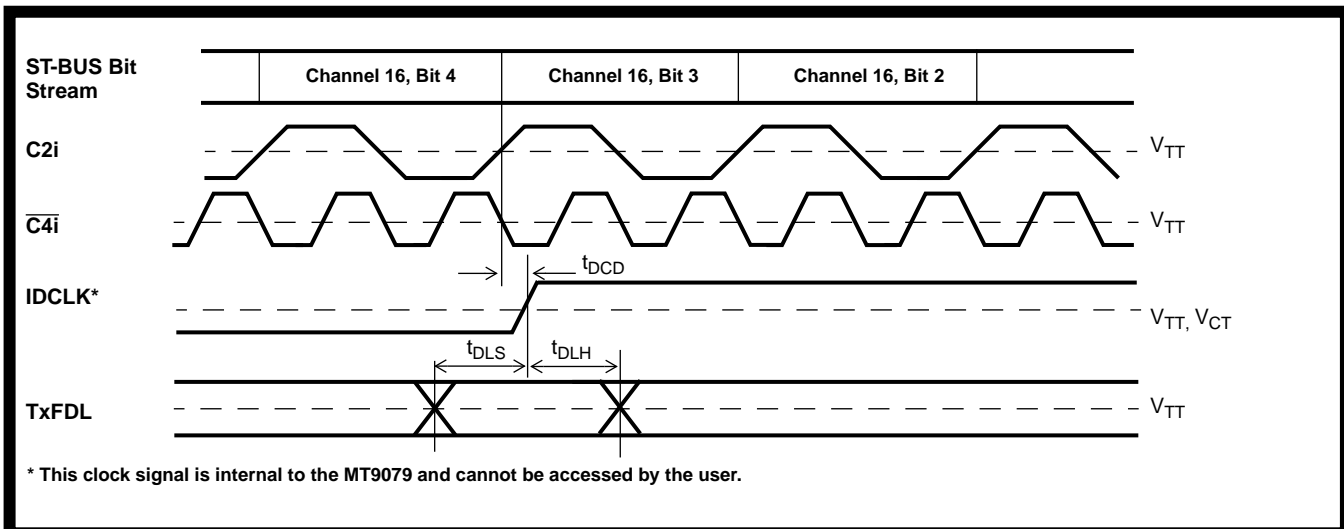

Figure 20 - Receive Data Link Timing Diagram



\* This clock signal is internal to the MT9079 and cannot be accessed by the user.

Figure 21 - Transmit Data Link Timing Diagram



AC Electrical Characteristics - ST-BUS Timing

	Characteristic	Sym	Min	Typ	Max	Units	Conditions/Notes
1	C2i Clock Width High or Low	$t_{2W}$	200		258	ns	C2i clock period = 458 ns
2	$\overline{C4i}$ Clock Width High or Low	$t_{4W}$	85		159	ns	$\overline{C4i}$ clock period = 244 ns
3	Frame Pulse Setup	$t_{FPS}$	10			ns	
4	Frame Pulse Low	$t_{FPL}$	20			ns	
5	Serial Input Setup	$t_{SIS}$	20			ns	
6	Serial Input Hold	$t_{SIH}$	30			ns	
7	Serial Output Delay	$t_{SOD}$			75	ns	150pF

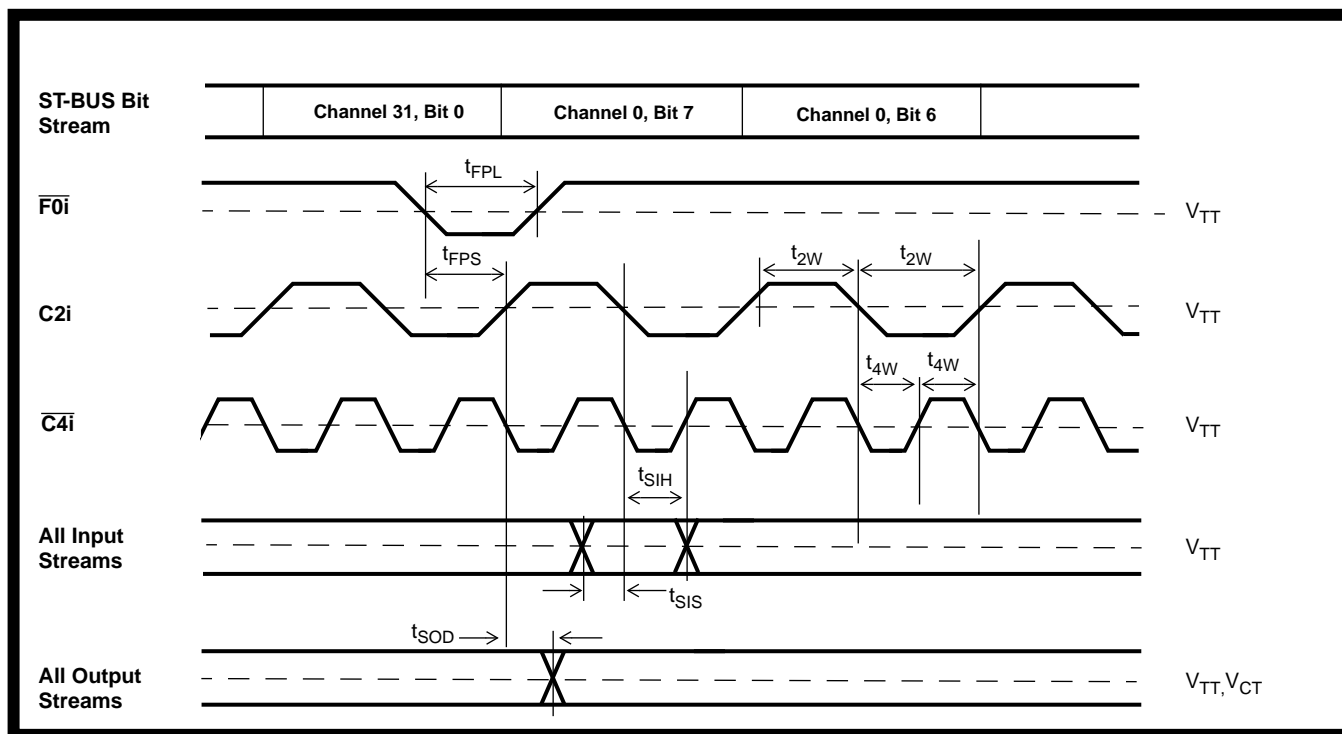

Figure 22 - ST-BUS Timing Diagram

AC Electrical Characteristics - Multiframe Timing

	Characteristic	Sym	Min	Typ	Max	Units	Conditions/Notes
1	Receive Multiframe Output Delay	$t_{MOD}$			75	ns	150pF
2	Transmit Multiframe Setup	$t_{MS}$	5			ns	
3	Transmit Multiframe Hold	$t_{MH}$	50		*	ns	* 256 C2 periods -100nsec
4	Multiframe to C2 Setup	$t_{MH2}$	100			ns	

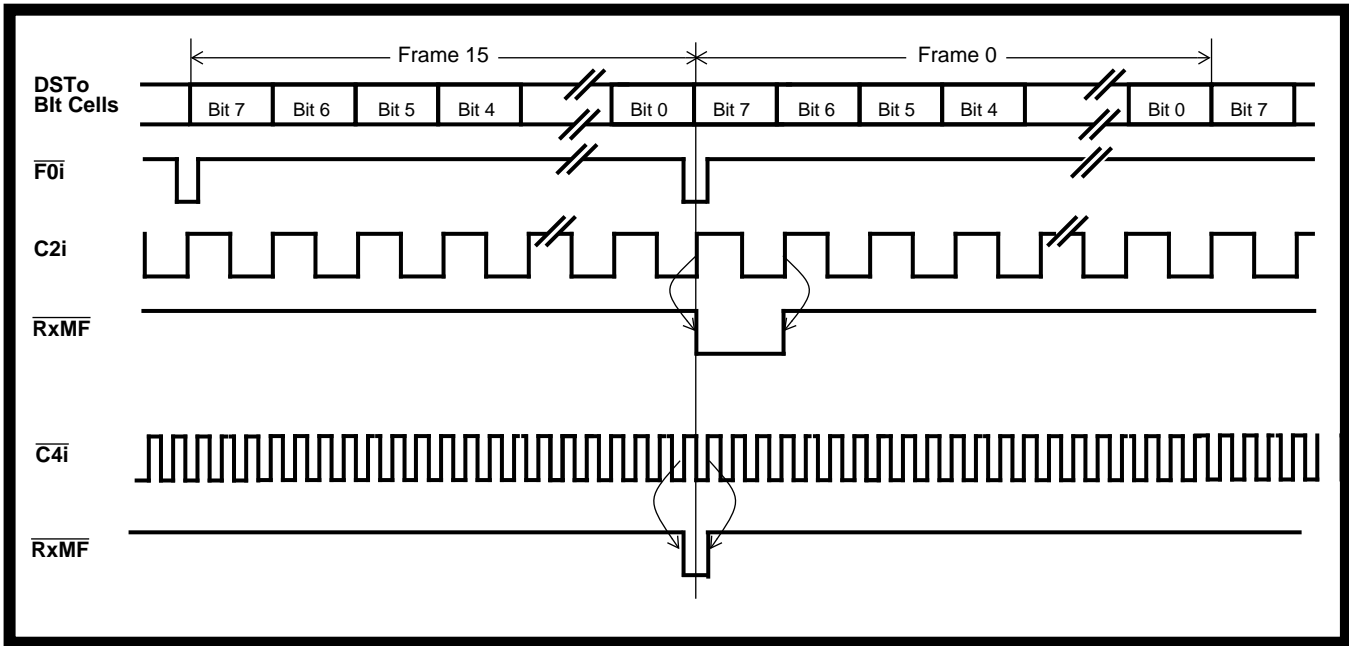

Figure 23 - Receive Multiframe Functional Timing

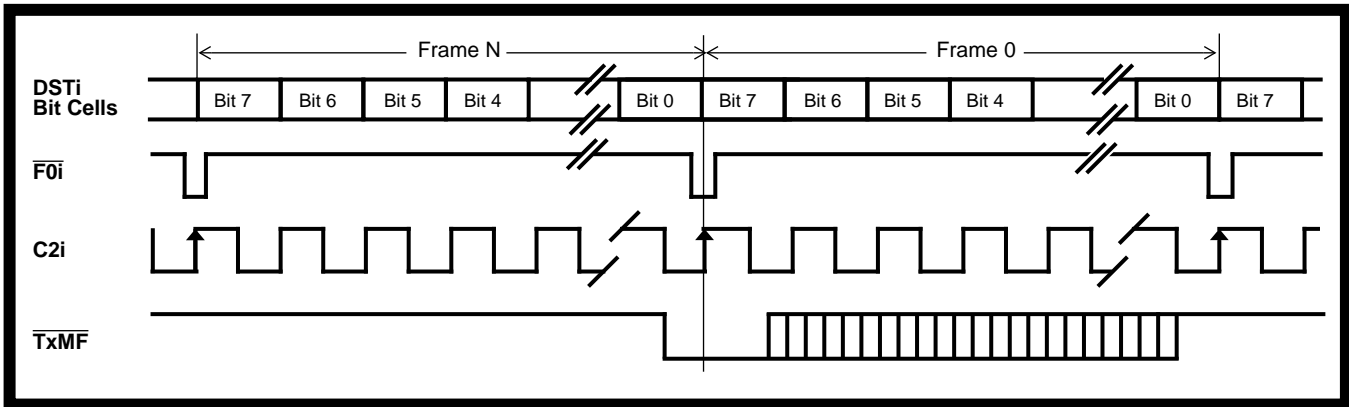

Figure 24 - Transmit Multiframe Functional Timing

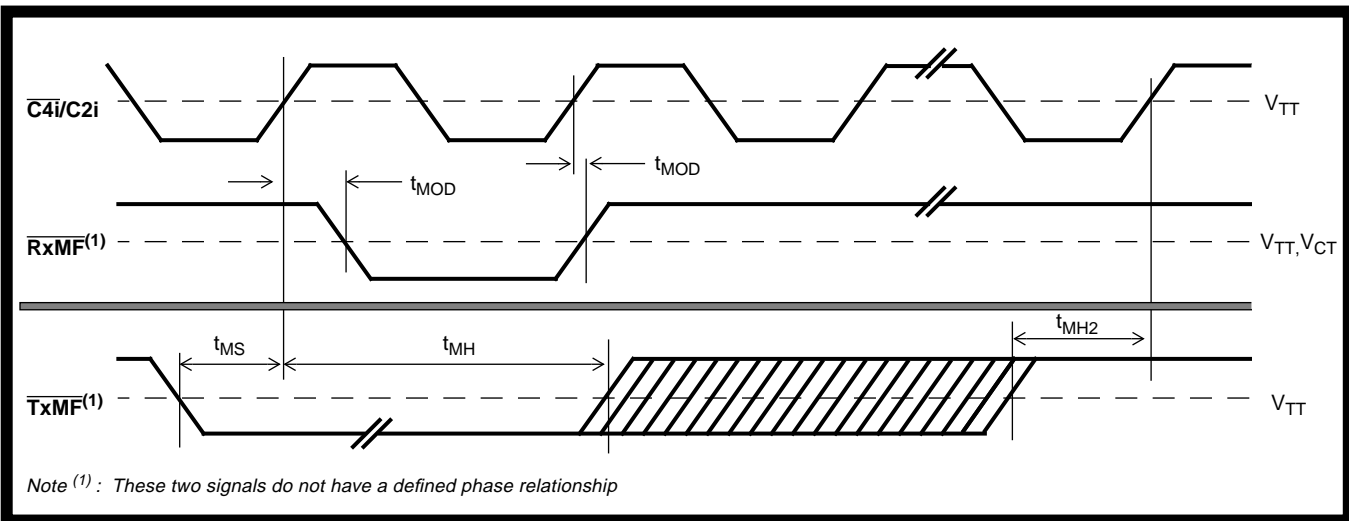

Figure 25 - Multiframe Timing Diagram ( $\overline{C4i}/C2i = 2.048 \text{ MHz}$ )

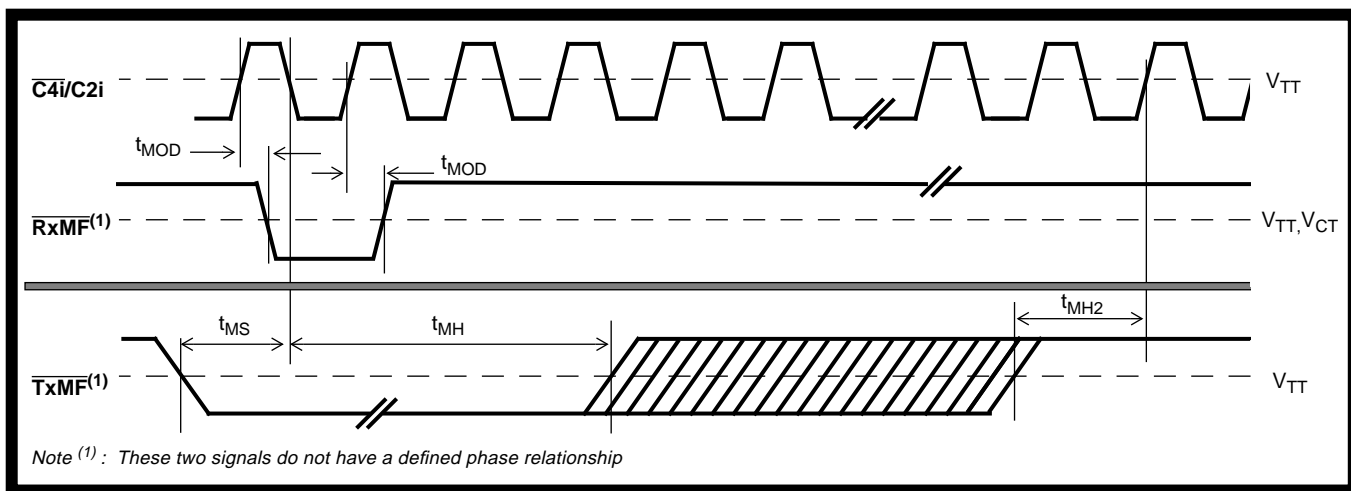

Figure 26 - Multiframe Timing Diagram ( $C4i/C2i = 4.096 \text{ MHz}$ )

AC Electrical Characteristics - E8Ko Timing

	Characteristic	Sym	Min	Typ	Max	Units	Conditions/Notes
1	E8Ko Output Delay	$t_{8OD}$			75	ns	150pF
2	E8Ko Pulse Width	$t_{8W}$				$\mu\text{s}$	62.5 $\mu\text{sec}$ typical
3	E8Ko Transition Time	$t_{8T}$			10	ns	50pF

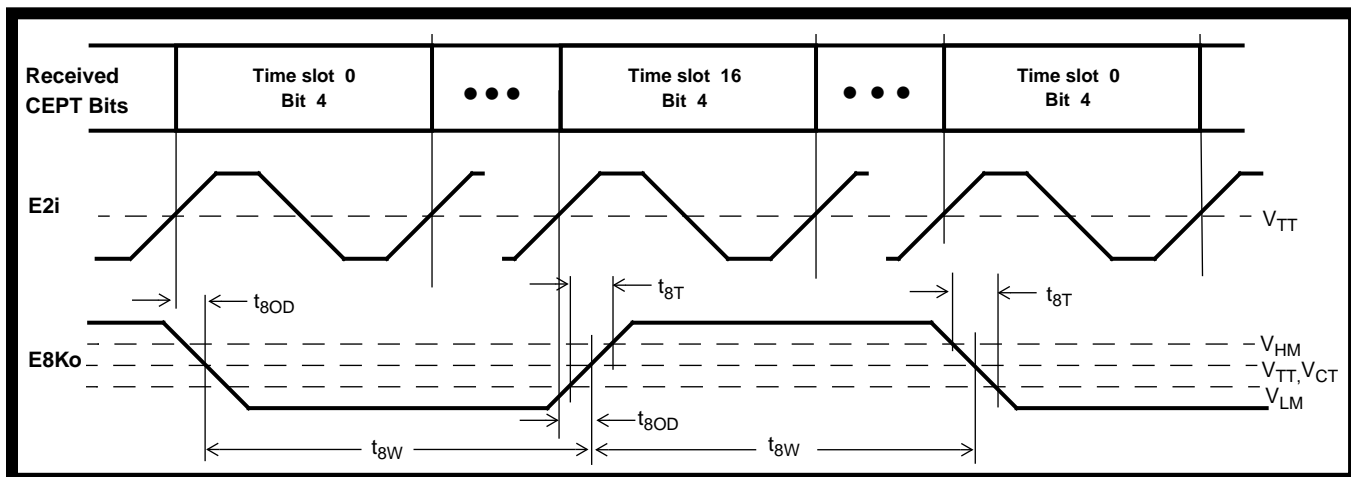

Figure 27 - E8Ko Timing Diagram

## AC Electrical Characteristics - PCM 30 Transmit Timing

	Characteristic	Sym	Min	Typ	Max	Units	Conditions/Notes
1	Transmit Delay	$t_{TDN}$			75	ns	150pF
2	Transmit Delay RZ	$t_{TDR}$			75	ns	150pF

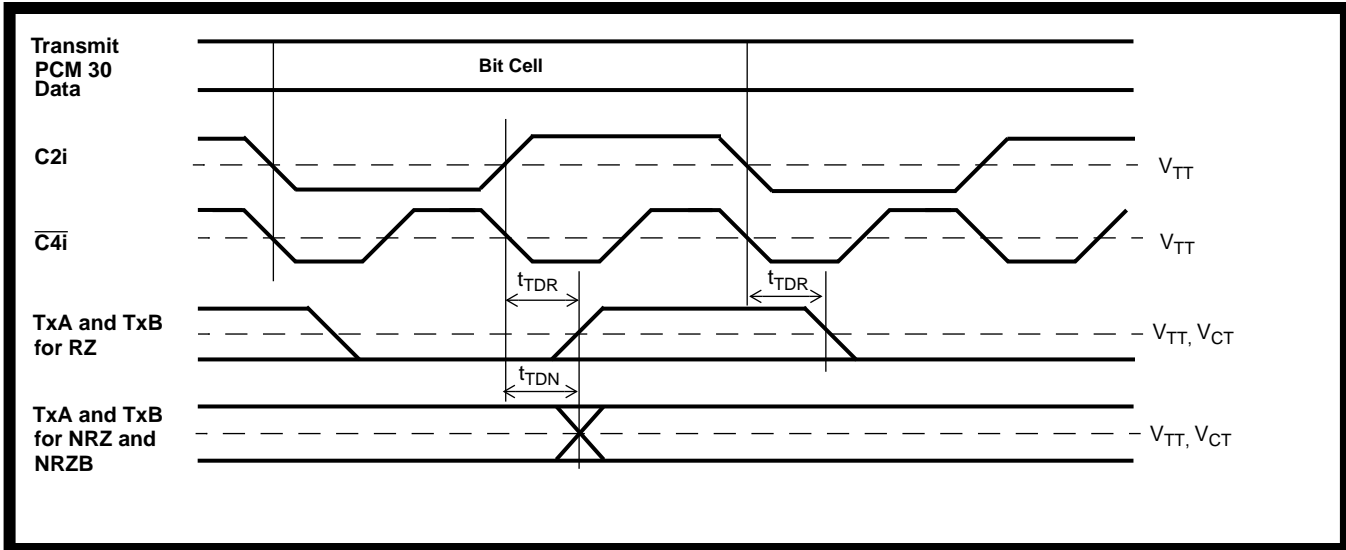

Figure 28 - PCM 30 Transmit Timing

## AC Electrical Characteristics - PCM 30 Receive Timing

	Characteristic	Sym	Min	Typ	Max	Units	Conditions/Notes
1	E2i Clock Pulse Width High or Low	$t_{CPW}$	50		438	ns	E2i clock period = 488nsec
2	Receive Setup Time	$t_{RS}$	10			ns	
3	Receive Hold Time	$t_{RH}$	10			ns	

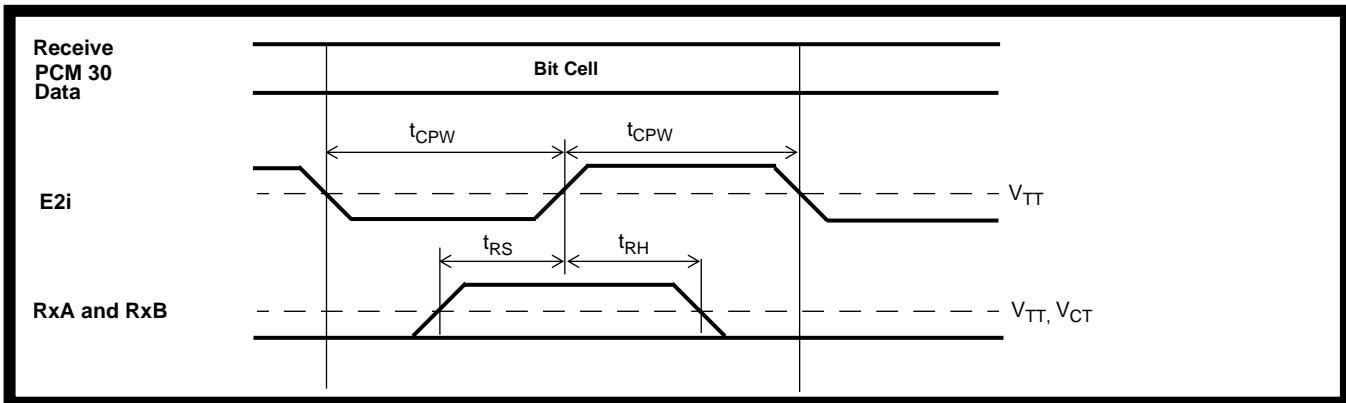

Figure 29 - PCM 30 Receive Timing

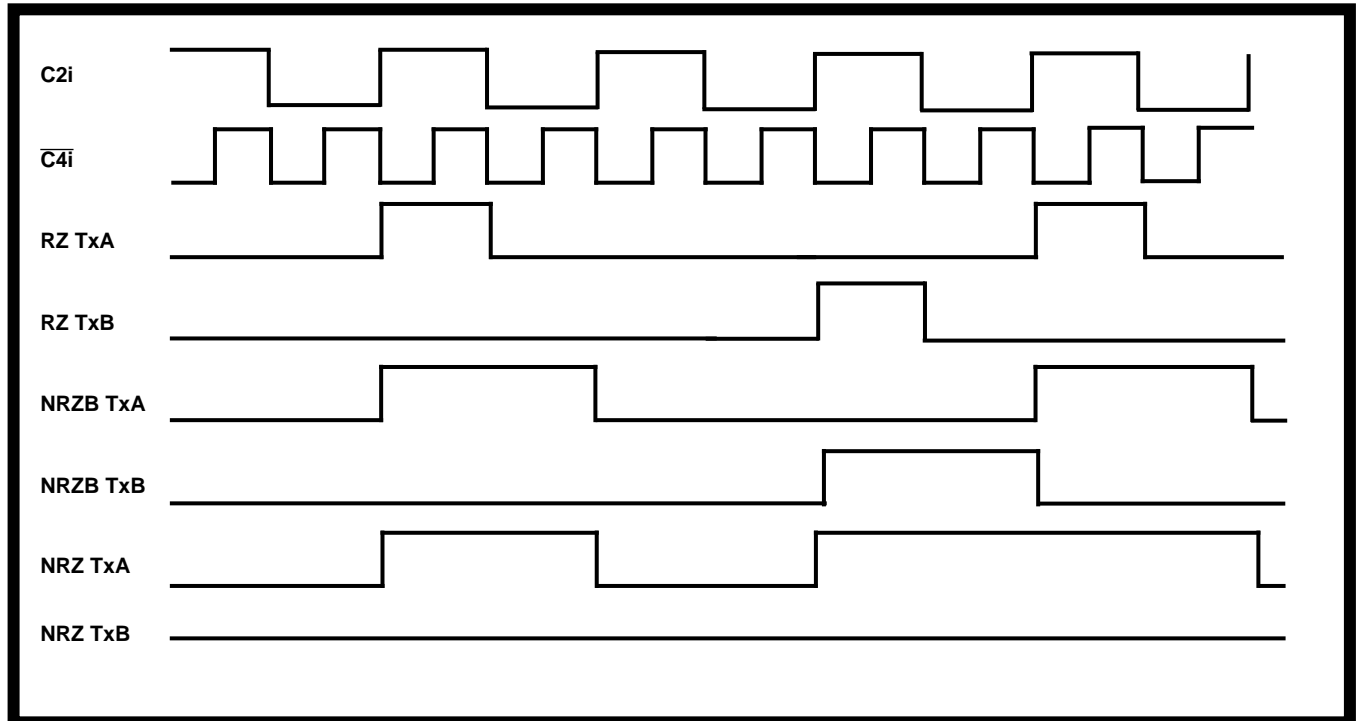

Figure 30 - Transmit Functional Timing

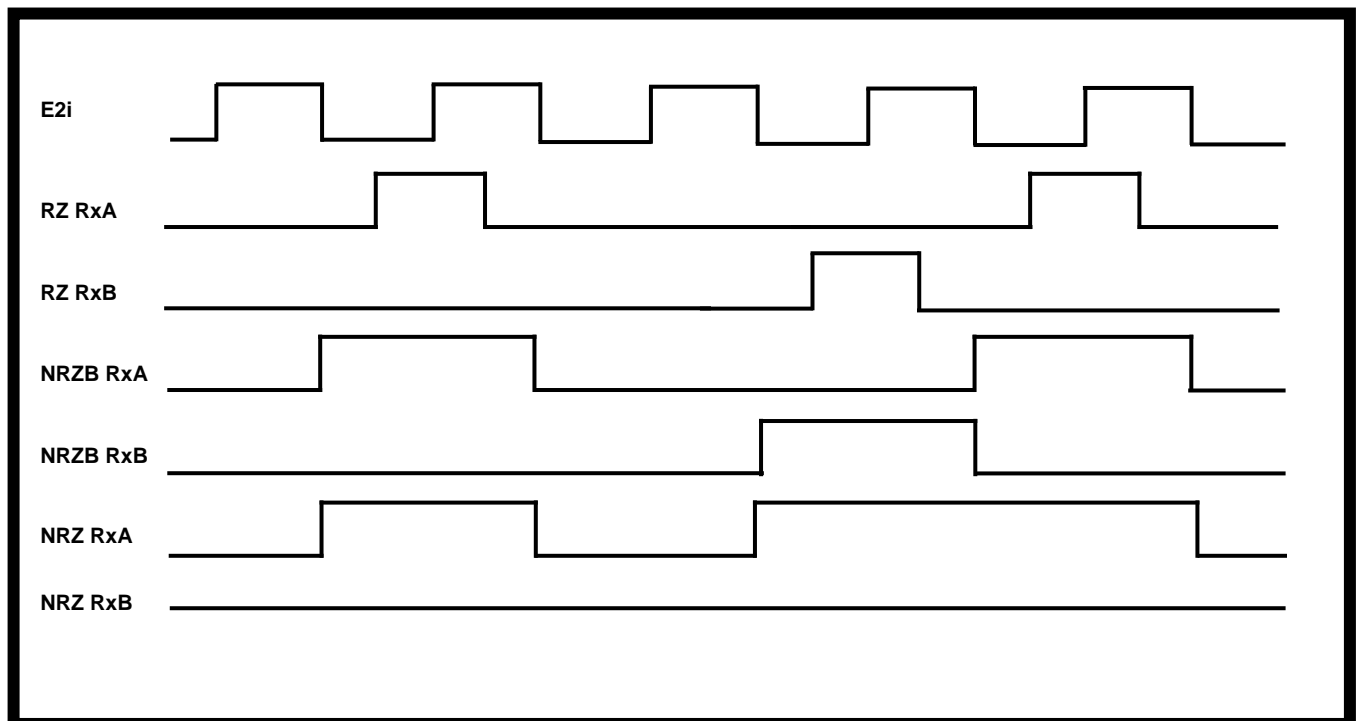

Figure 31 - Receive Functional Timing

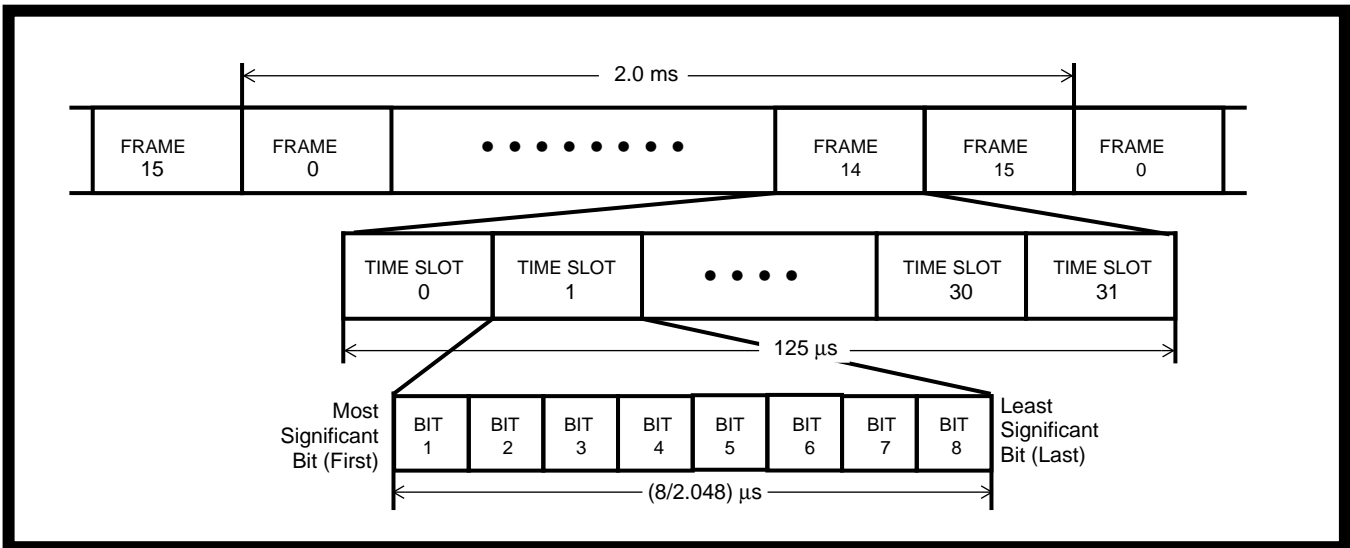

Figure 32 - PCM 30 Format

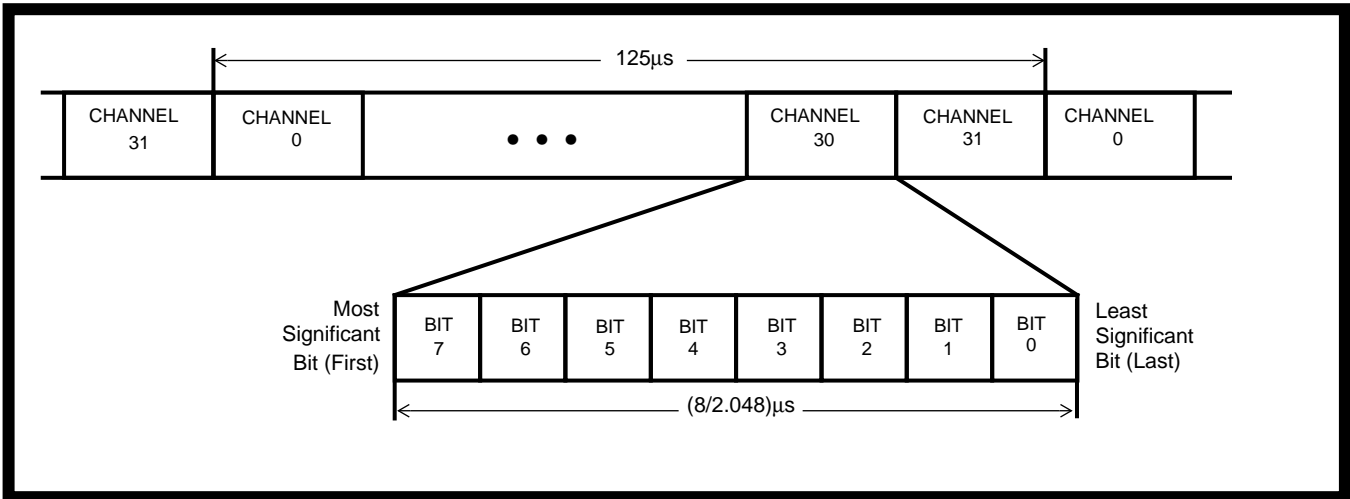

Figure 33 - ST-BUS Stream Format